

Mobile Cart End Covers

Product Numbers

- MFCxx

Hardware Pack: MFCHP (p/n 93082704-01)

Required Tools

- $\frac{5}{32}$ " Allen Wrench

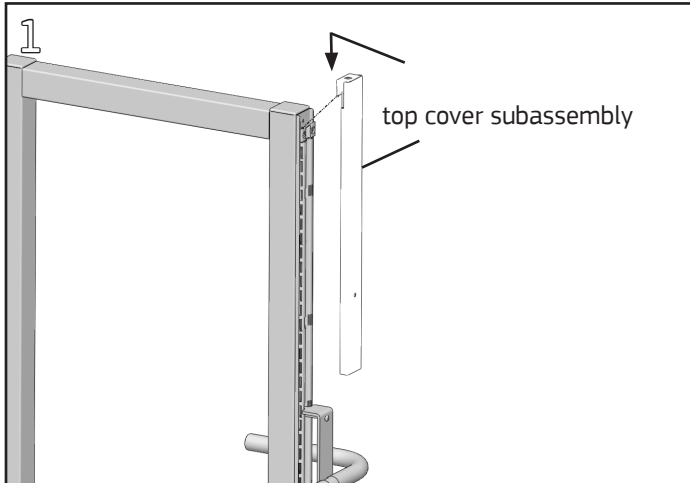

Hook top cover subassembly (shorter cover) over the top wedge block on the end of the Mobile Cart.

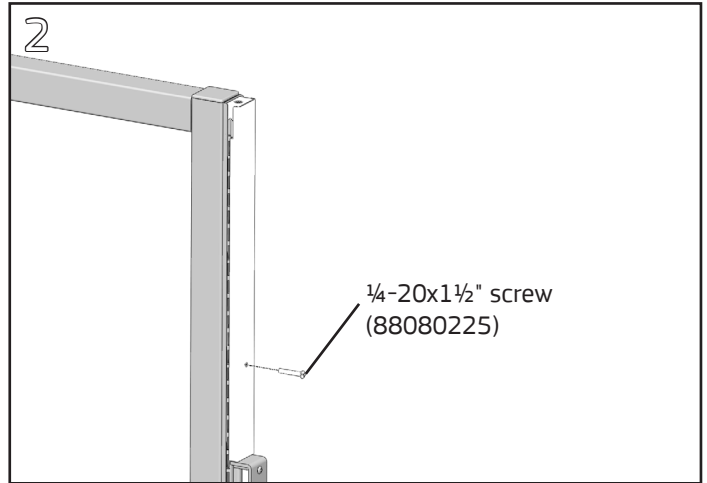

Fasten cover with a $\frac{1}{4}$ -20x1 $\frac{1}{2}$ " socket button head cap screw using a $\frac{5}{32}$ " Allen wrench.

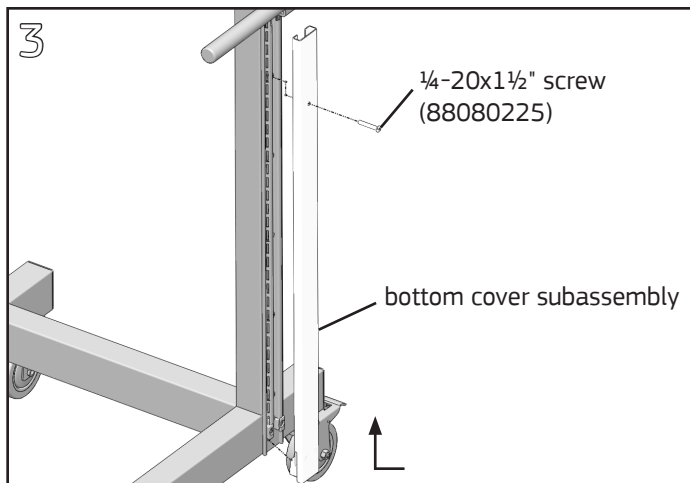

Hook bottom cover subassembly over the bottom wedge block and fasten (2) $\frac{1}{4}$ -20 screws using a $\frac{5}{32}$ " Allen wrench.



Repeat steps 1 through 3 on opposite side of the Mobile Cart.