

Panel Frame to Connector Post

Product Numbers

- CPMxx, CPExx
- C90xx, C3xx, C4xx

Required Tools

- 1/4" Allen Wrench or 1/4" Hex Bit with driver

Hardware Pack: none

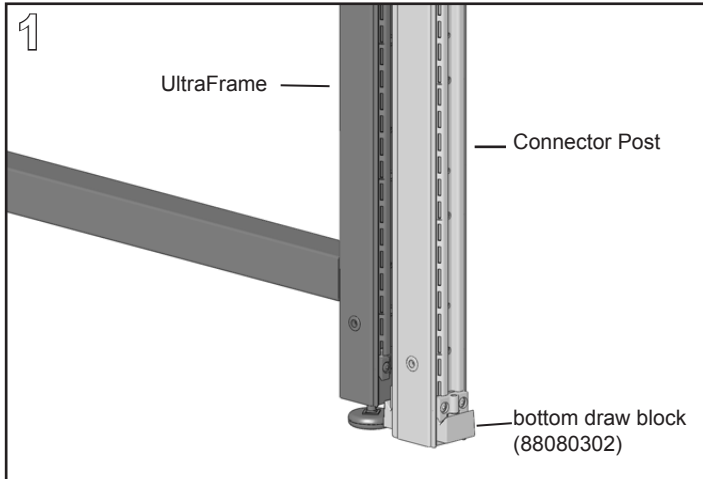

Align the Connector Post or Corner Connector with the frame. Place the bottom draw block of the connector directly below the bottom wedge block of the frame.

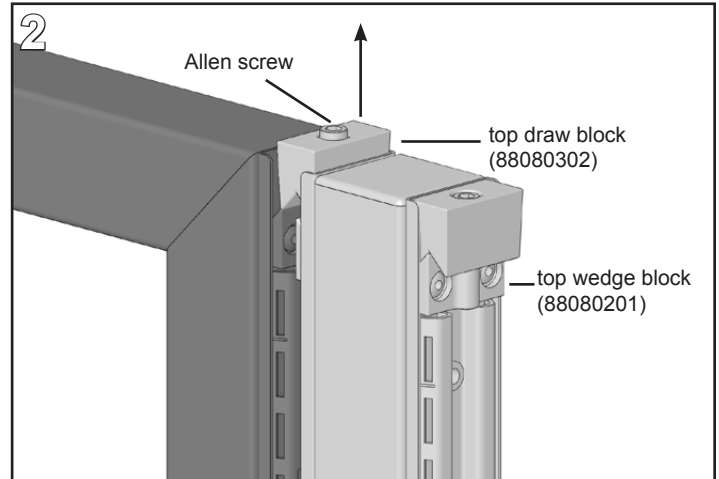

Pull up on the top draw block while loosening the Allen screw in the top with a 1/4" **Allen Wrench/bit** until the top draw block clears the top wedge block of the frame. Drop the draw block over the tops of both the frame and connector wedge blocks.

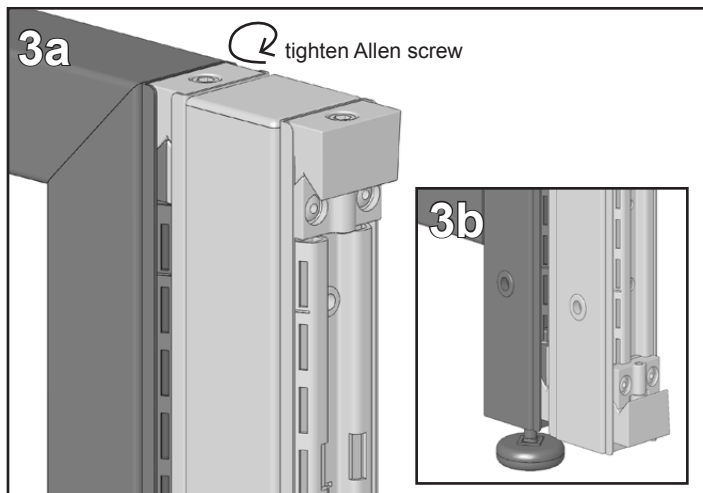

Tighten Allen screw in the top of the connector (3a) to 6-14 foot-lbs. Ensure the bottom draw block of the connector (3b) captures the bottom wedge block of the frame as it is tightened.

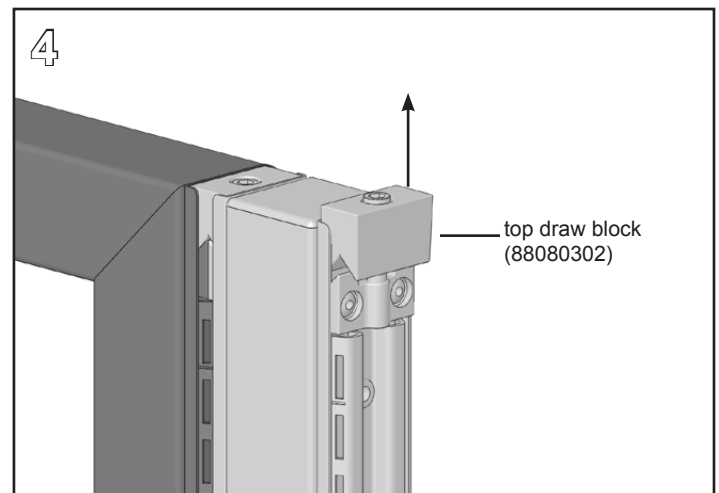

On the opposite end of the connector, pull up on the top draw block while loosening the Allen screw in the top until it clears the top wedge block of the connector.

Panel Frame to Connector Post

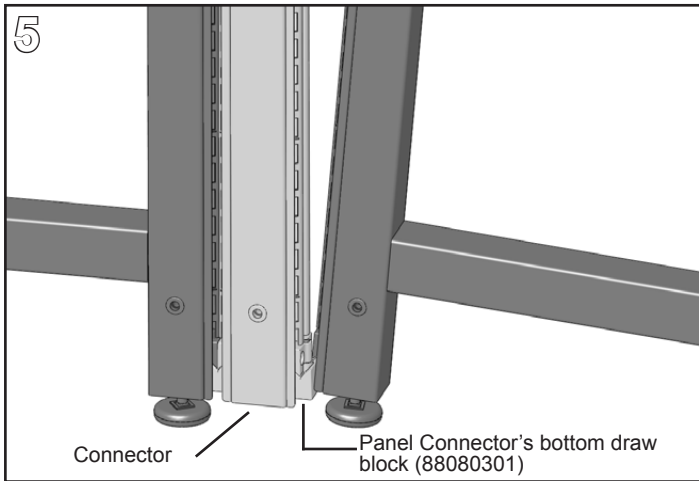

Align the next frame with the connector and then lift the bottom end of the frame up and over the bottom draw block of the connector so the bottom wedge block of the frame rests on the draw block of the connector.

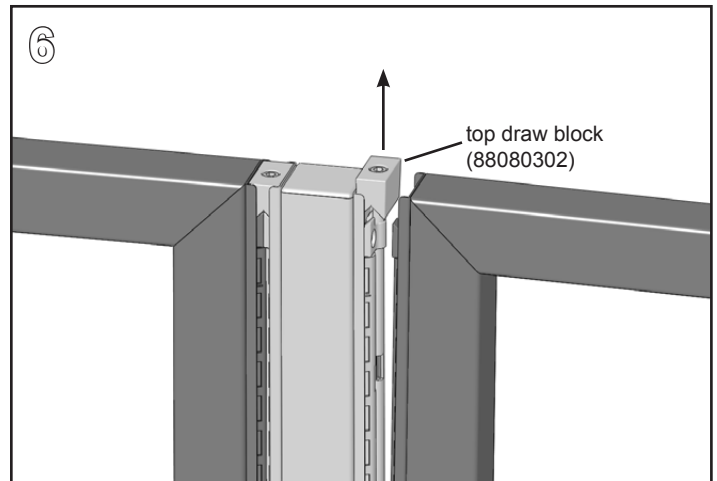

Pull up on the top draw block of the connector. Push the top of the frame toward the connector then drop the top draw block over the top of both the frame and connector wedge blocks.

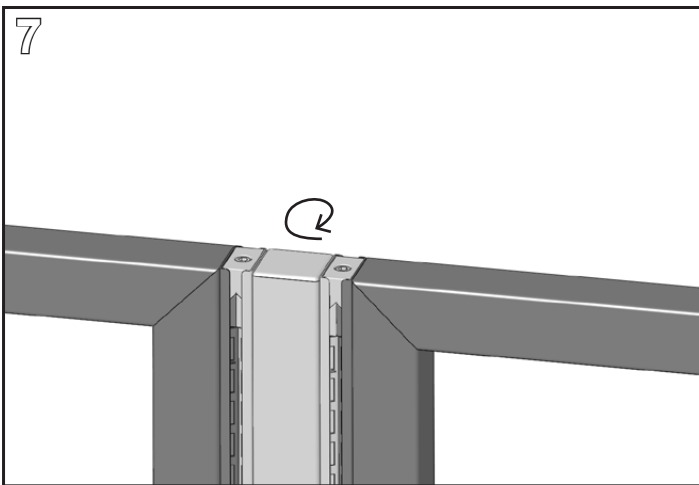

Tighten Allen screw in the top of the connector to 6-14 foot-lbs.