

Laminate Grounding Terminal

Product Numbers

- UDRxxyy, UCDRxxyy
- UDSxxyy, UCDSxxyy
- UDTxxyy, UCDTxxyy
- SDSxxyy, SCDSxxyy
- SDRxxyy, SCDRxxyy

Required Tools

- Rubber Mallet
- #2 Phillips Screwdriver

Hardware Pack: LGT3 (p/n 90070604)

Note: To ensure ground path continuity, install as indicated in all dissipative laminate surfaces. Removing and reinstalling the laminate grounding terminal may cancel the grounding characteristics of the assembly. Continuity should be verified if bolt has been modified.

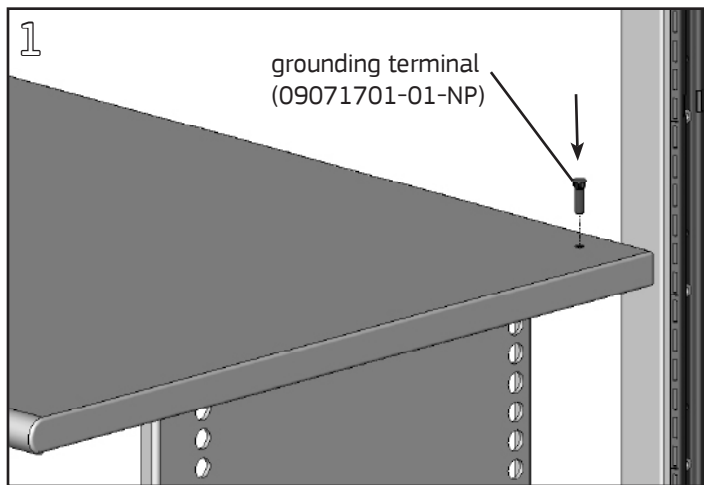

Using a rubber mallet, lightly tap the grounding terminal into the hole in the top of the surface.

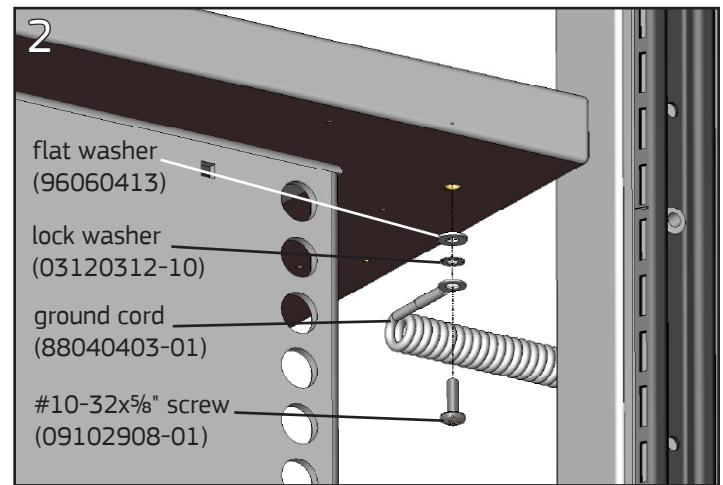

From below the surface, assemble the #10-32x5/8" Phillips pan head SEMS screw with the grounding cord, then a #10 external tooth lockwasher and #10 flat washer. Fasten the screw into the bottom of the grounding terminal using a #2 Phillips screwdriver.

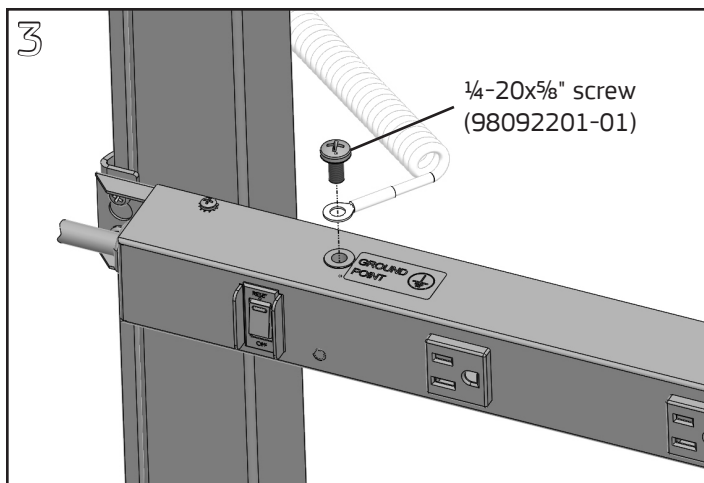

Attach the other end of the ground cord to a verified grounding point location.

ESD Laminate Cleaning Instructions

Nevamar® high pressure laminate can be cleaned using a damp cloth or sponge with a mild soap or non-bleach detergent. Ammoniated or vinegar-based glass cleaners are best for cleaning surfaces soiled by grease. Nevamar does not recommend the use of any cleaners with bleach or antibacterial formulas as they may damage the finish. Abrasive cleaners or abrasive coated scouring pads should not be used as they may permanently dull or scratch the surface. A soft bristle nylon brush can be used if necessary.