

# ErgoStat® Pro

## BASES AND RISER FRAMES

### Synchronization and Ganging Kit

#### PRODUCT NUMBERS

PSYK

#### HARDWARE PACK

p/n 17052504-10 and 17052505-01

#### REQUIRED TOOLS

#2 Phillips Screwdriver

#2 Phillips Bit with Cordless Drill Driver

1/8" Drill Bit

Note: Up to four ErgoStat Pro bases can be synchronized. A hand control can be used on either end of the adjacent base run. When synchronizing more than two bases the hand control/s on the center base/s must be removed *after step 1* so connections can be made at port "A1" instead of "A2".

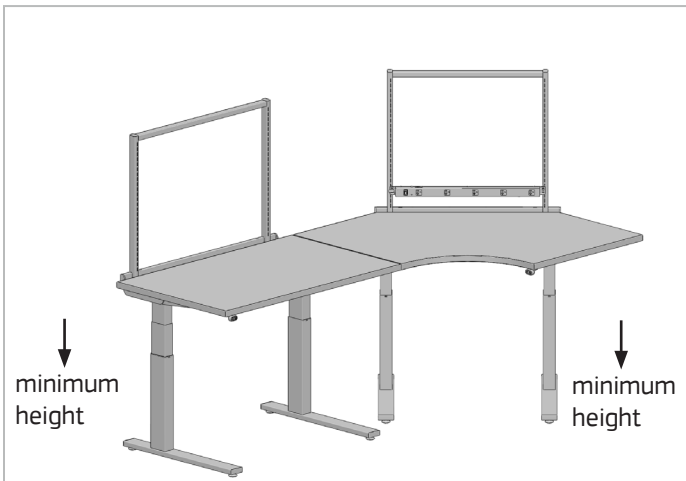

1. Assemble top surfaces to ErgoStat Pro Bases to be synchronized per installation instructions. Lower both bases to minimum height.

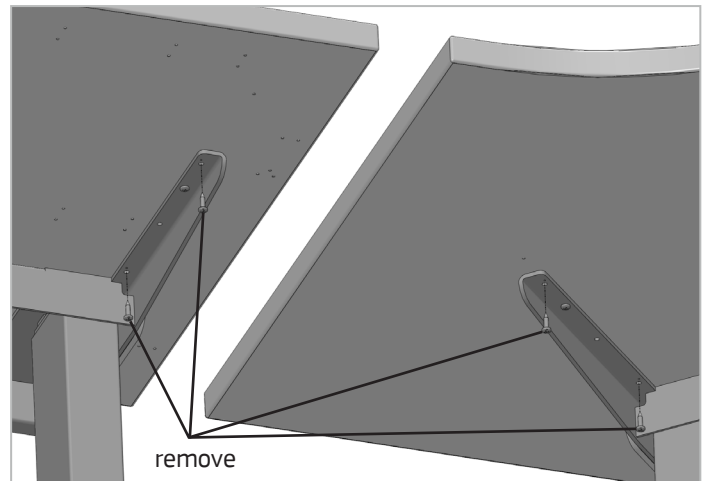

2. Remove the front screw and screw closest to the stretcher on the adjacent top support of each ErgoStat Pro Base using a #2 Phillips screwdriver.

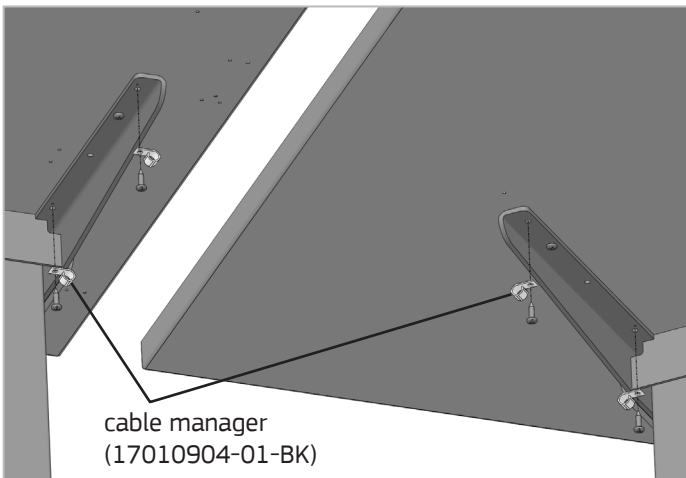

3. Reinstall each screw with a cable manager attached on each ErgoStat Pro Base.

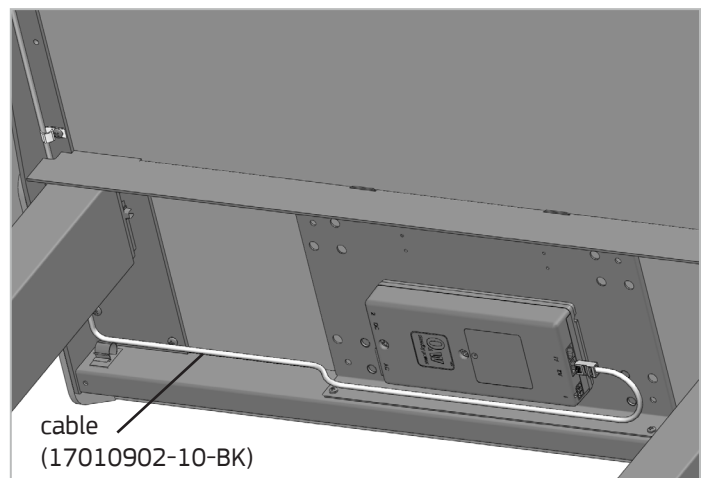

4. Connect 10' black cable to the port labeled "A2" on one of the bases. Route cable alongside the leg and through the front stretcher notch of the first base. Insert the cable in the cable manager locations.

## BASES AND RISER FRAMES

### Synchronization and Ganging Kit, continued

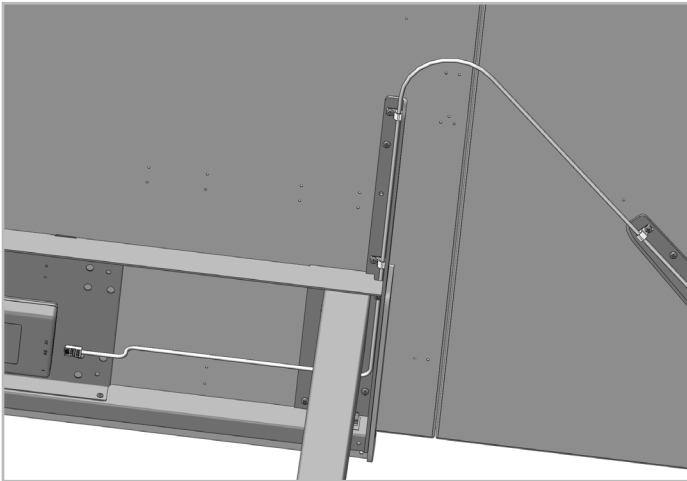

5. Continue routing the cable through the cable managers along the bracket of the adjacent ErgoStat Pro Base, through the front stretcher notch, and inside the stretcher of the adjacent base, plugging other end of the cable into port "A2" on the second base. Manage excess cable with stretcher cord managers.

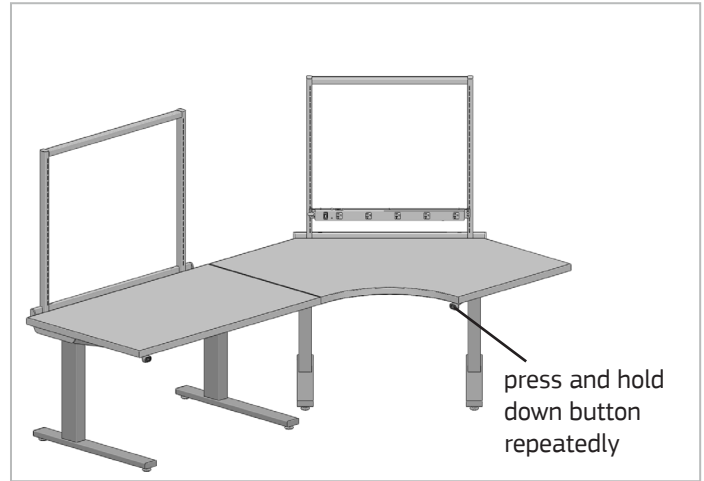

6. To properly initialize the synchronization of the bases, press and hold the down button on the control switch of either hand control until the bases come to a complete stop in the lowest position. Release the down button and wait 2-3 seconds. Then press the down button again.

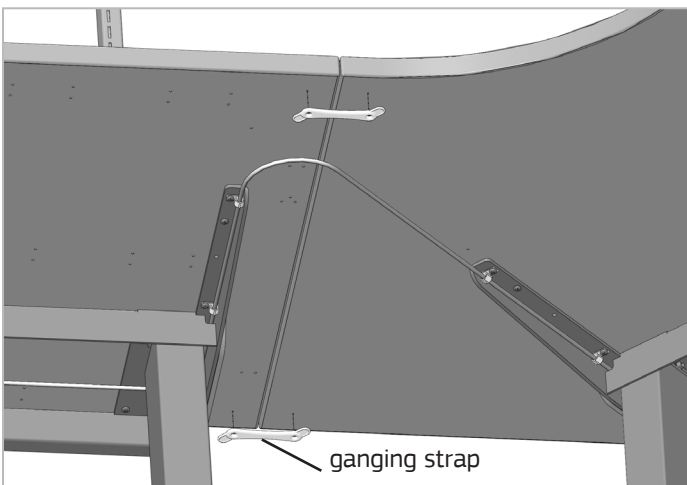

7. Align the top surfaces as desired. Use the ganging straps to mark appropriate pilot locations near the front and back corners of the surface joint. Drill pilot holes using a  $\frac{1}{8}$ " drill bit and cordless drill/driver.

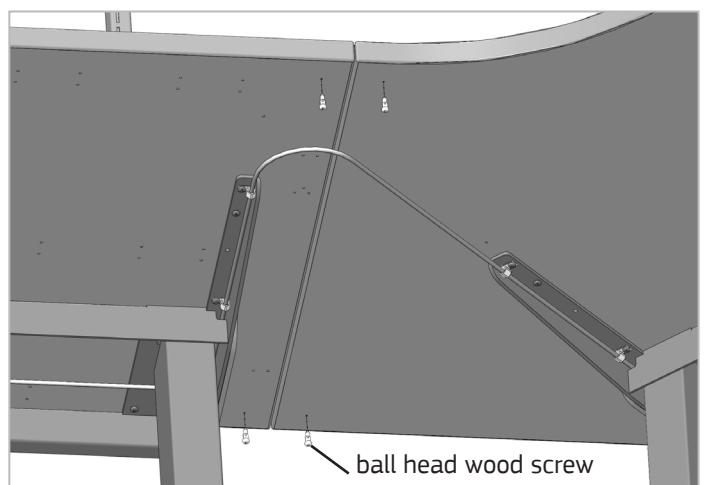

8. Install a ball head wood screw into each pilot hole using a #2 Phillips screwdriver/bit.

## BASES AND RISER FRAMES

### Synchronization and Ganging Kit, continued

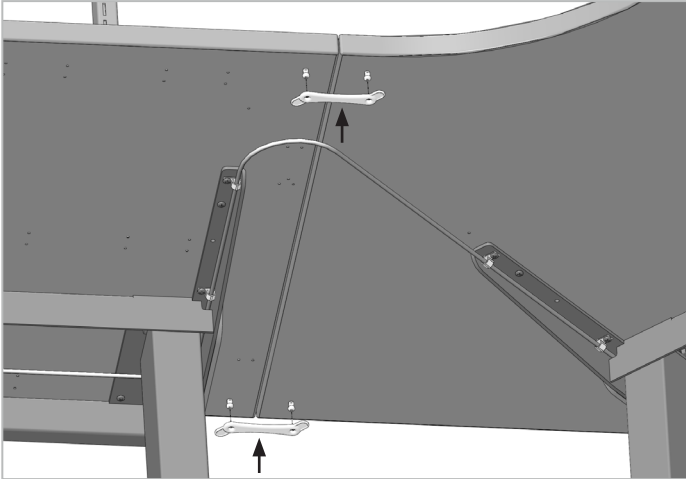

9. Slide ganging straps over each pair of ball head wood screws.