

Electrical Distributor Inset-Mount Cover, 3-way

Product Numbers

- EDCN3

Hardware Pack: EDCN3 (p/n 12022503-01)

Required Tools:

- #2 Phillips Screwdriver
- ¼" Wrench

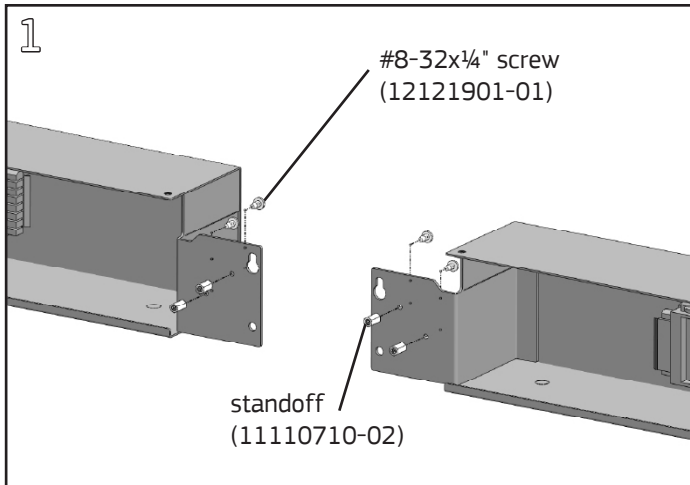

Before installing the Electrical Distributors on the frames, install a #8-32x¼" Phillips panhead screw in each tapped hole of the distributor base end near the 3-way frame connection. Fasten a hex stand-off to the end of each screw and tighten with a ¼" wrench and #2 Phillips screwdriver.

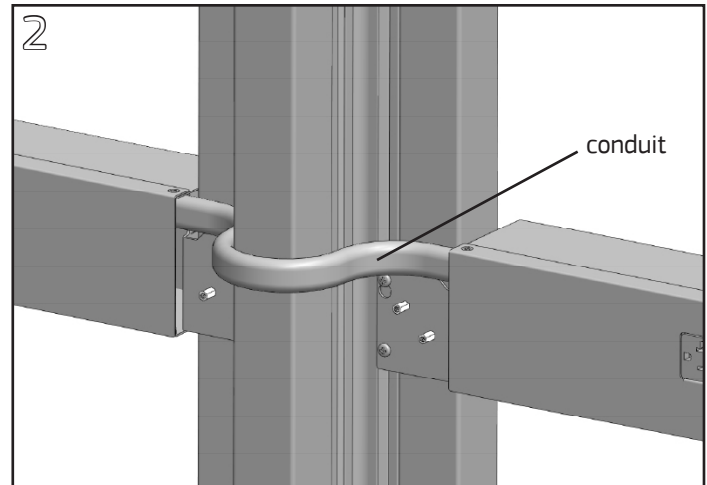

Install Electrical Distributors and Jumper Cable per individual product installation instructions. Route the Jumper Cable conduit above the Electrical Distributor hanger clips.

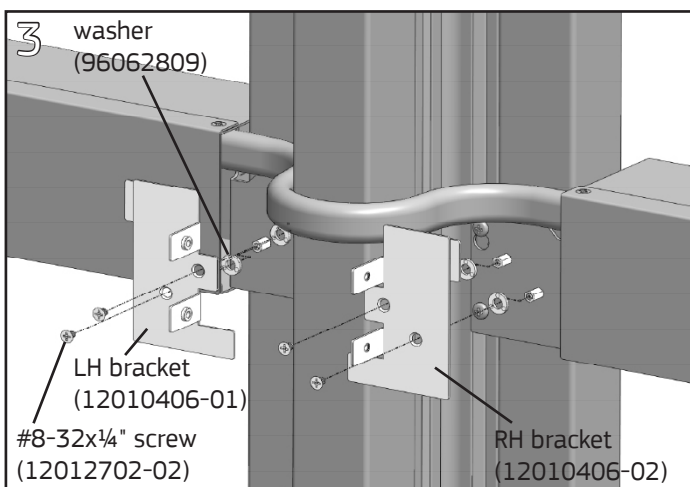

Place a bracket on each side of the frame joint, tucking the tab behind the adjacent Electrical Distributor cover. Insert a #8-32x¼" Phillips flathead screw through each countersunk hole in the brackets, then a nylon washer, and align them with the tapped hole in the hex standoff. Tighten screws with a #2 Phillips screwdriver.

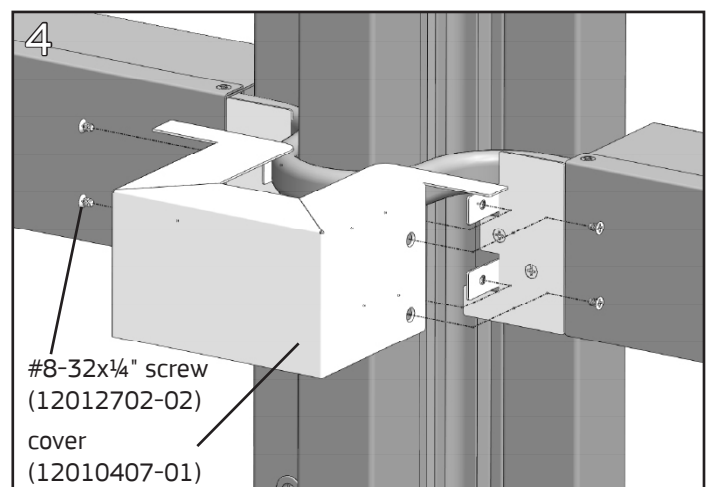

Slide the cover over the flange of the right and left brackets. Install a #8-32x¼" Phillips flathead screw through the countersunk holes of the cover and tighten with a #2 Phillips screwdriver.