

Surface Accessory Brackets, Short

Product Numbers

- SRCSBK

Hardware Pack: n/a

Required Tools

- 1/8" Drill Bit or 11/64" Drill Bit
- #2 Phillips Screwdriver and/or #2 Phillips Bit
- Cordless Drill/Driver

WARNING: Do not tighten the #10-12 surface screws more than 25 in-lbs. in laminated surfaces or 40 in-lbs. in phenolic surfaces. Drill 1/8" diameter pilot holes for laminated surfaces or 11/64" diameter pilot holes for phenolic surfaces.

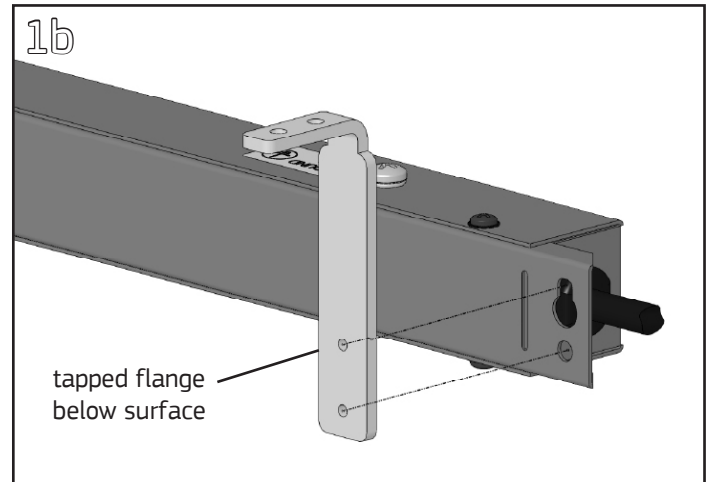
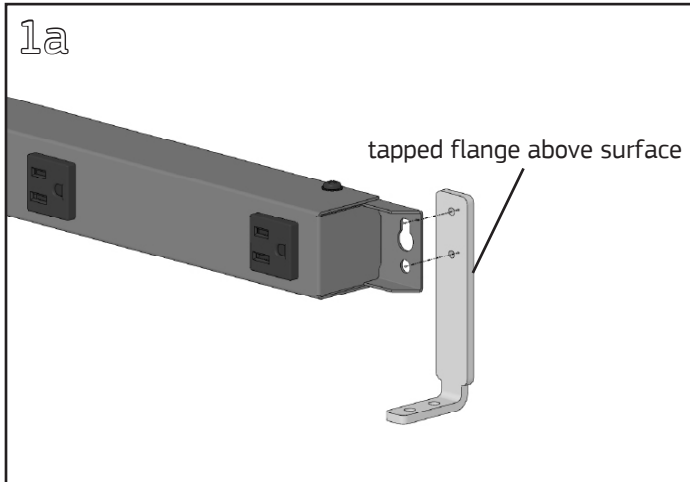

Align the keyslot hole and lower hole on one end of the Electric Plug Strip with the two tapped holes in one of the Surface Accessory Brackets. The plug strip can be mounted on the front or back of the bracket and the bracket can be mounted with the tapped flange above or below the surface.

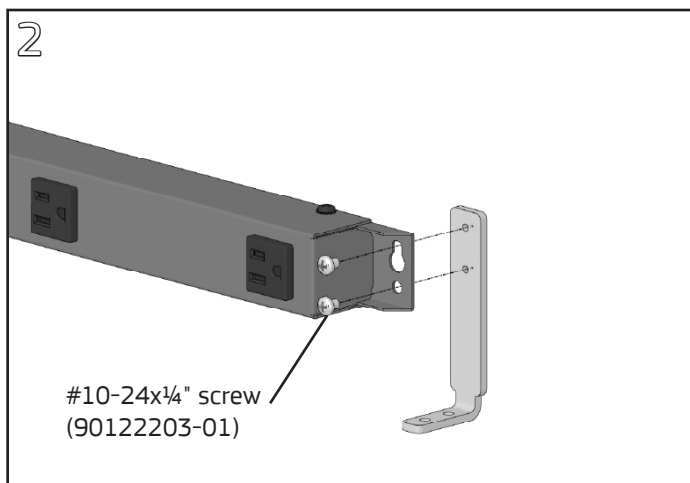

Fasten plug strip to bracket with (2) #10-24x1/4" Phillips pan head screws using a #2 Phillips screwdriver. Repeat on the opposite end of the plug strip.

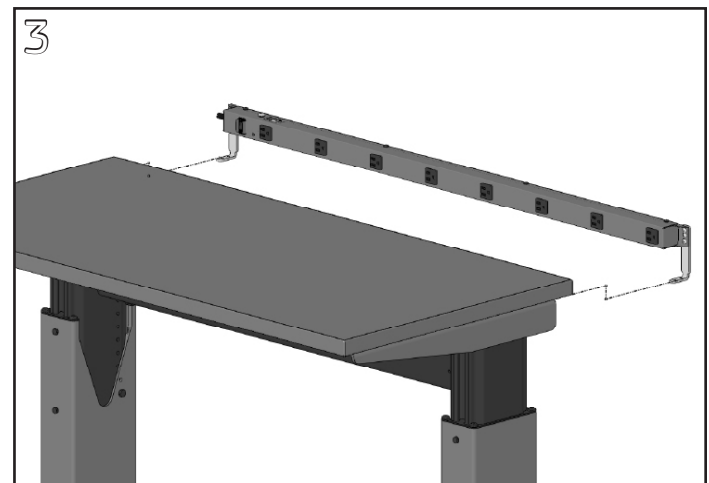

Install the work surface according to surface support instructions. Position the plug strip as desired with the flange and two thru holes held tight against the underside of the surface. Mark the hole locations on the underside of the surface for each bracket.

Surface Accessory Brackets, Short

WARNING: Do not tighten the #10-12 surface screws more than 25 in-lbs. in laminated surfaces or 40 in-lbs. in phenolic surfaces. Drill $\frac{1}{8}$ " diameter pilot holes for laminated surfaces or $\frac{11}{64}$ " diameter pilot holes for phenolic surfaces.

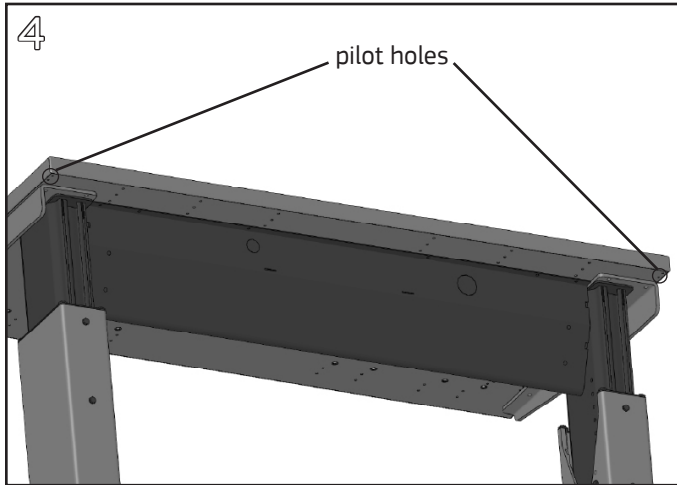

Using a drill bit and cordless drill, drill a pilot hole in the surface in the marked locations. Do not drill holes deeper than $\frac{3}{4}$ " to avoid puncturing the top of the work surface.

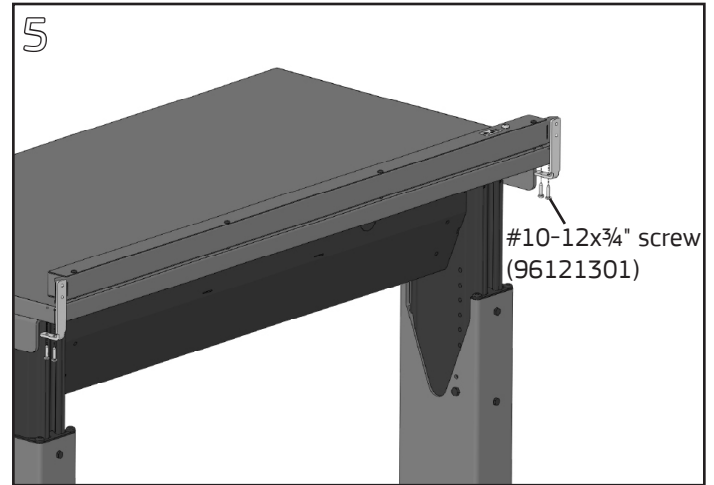

Reposition plug strip and fasten each bracket to the underside of the work surface with (2) #10-12x $\frac{3}{4}$ " Phillips pan head screws using a #2 screwdriver/ drill with bit.