

## Surface Reinforcement Bars

### Product Numbers

- WRBxx

Hardware Pack: WRBHP (p/n 10081301-01)

### Required Tools

- (2) 5mm Allen Wrenches
- Torque Wrench with 5mm Bit
- $\frac{3}{8}$ " Nut Driver
- $\frac{7}{16}$ " Nut Driver

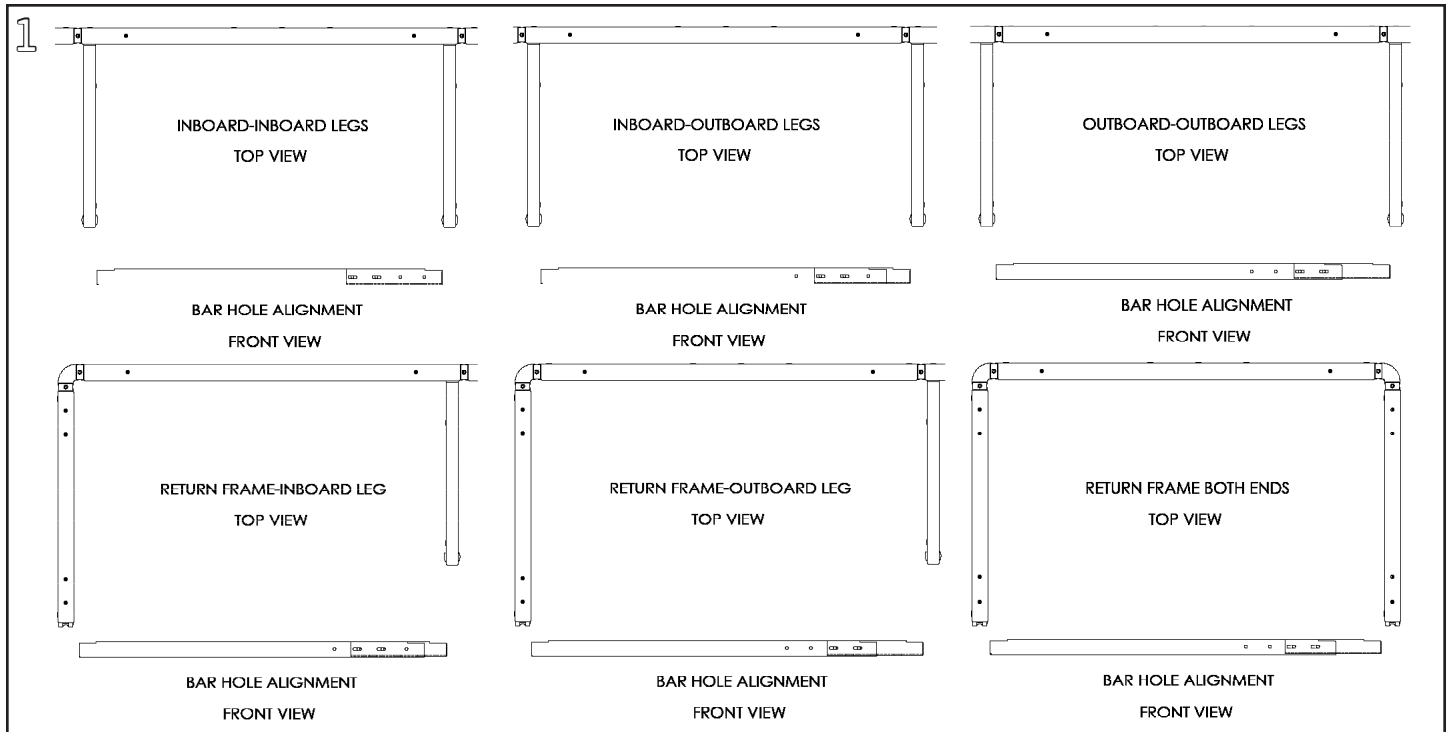

Determine leg configuration at location where Reinforcement Bars are to be installed. Note the required position of the slots in the inner channel relative to the holes in the outer channel shown in the corresponding “Bar Hole Alignment” views (the return frame-inboard leg configuration is shown throughout the remaining steps of these instructions).

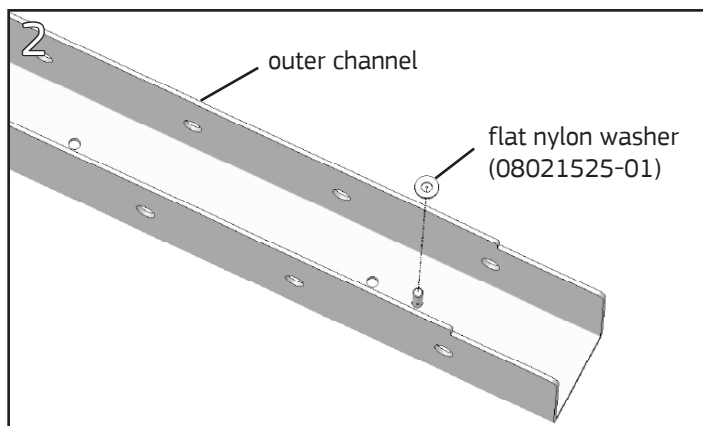

Place a nylon washer on the PEM stud on the outer channel of each reinforcement bar.

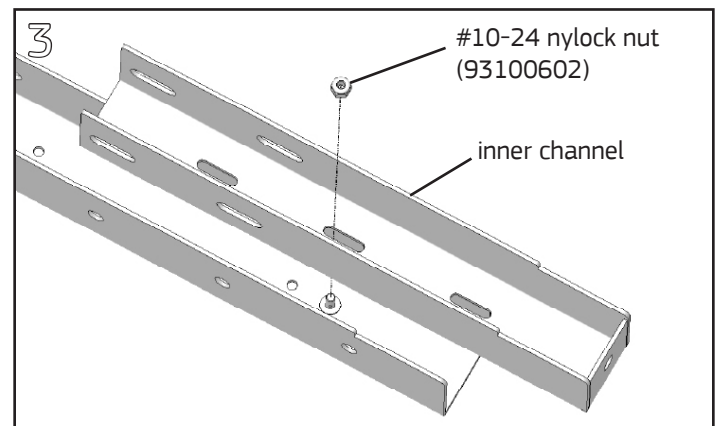

Position Reinforcement Bar inner channels on the inside of the outer channels as indicated in step 1. The PEM studs will align with one of the slots in the bottom of the inner channel. Loosely fasten with a #10-24 nylock nut.

## Surface Reinforcement Bars

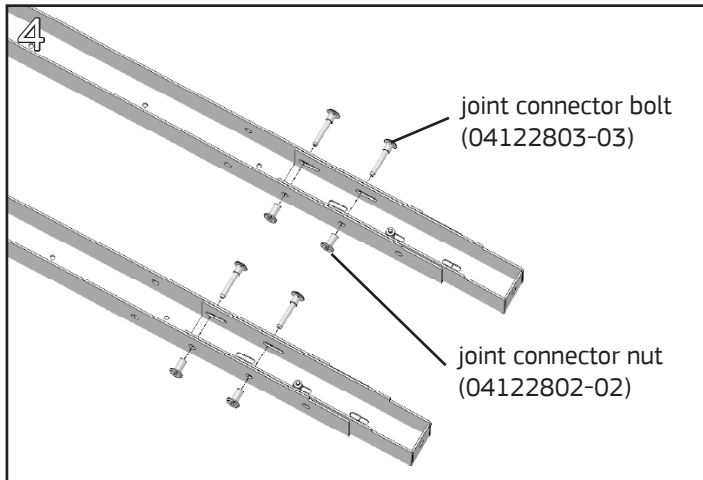

Insert a joint connector bolt and nut through the outer channel holes and through the appropriate inner channel slot location. Do not fully tighten.

5 Reinforcement Bar Length Setting

Configuration	End-to-End Length		
	48" Surface Width	60" Surface Width	72" Surface Width
Inboard-Inboard Legs	43 1/8"	55 1/8"	67 1/8"
Inboard-Outboard Legs	46 1/8"	58 1/8"	70 1/8"
Outboard-Outboard Legs	49 1/8"	61 1/8"	73 1/8"
Return Frame Both Ends	48 3/4"	60 3/4"	72 3/4"
Return Frame-Inboard Leg	46"	58"	70"

Based on the configurations shown in step 1 and the surface width to be mounted over the bars, slide the inner channel in or out of the outer channel until the end-to-end length of the Reinforcement Bar assemblies meet the dimension listed in the table above.

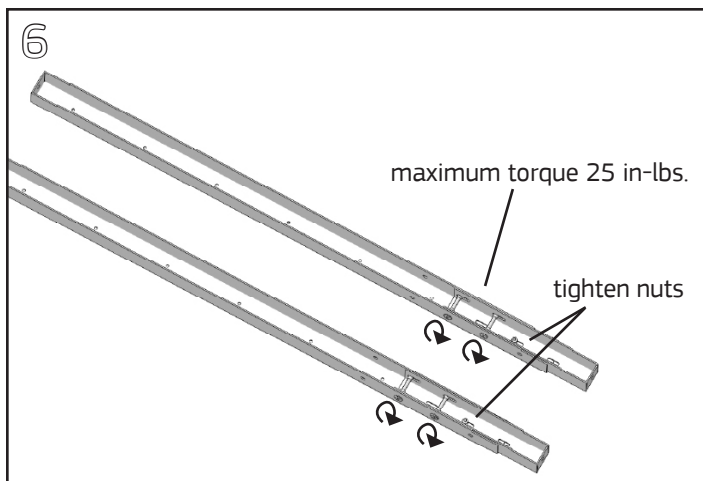

Tighten connections at the bar joints to a maximum torque of 25 in-lbs. using a **Torque Wrench** with **5mm Bit**. Then fully tighten the nut on the PEM stud in each of the channels with a **3/8" Nut Driver**.

## Surface Reinforcement Bars

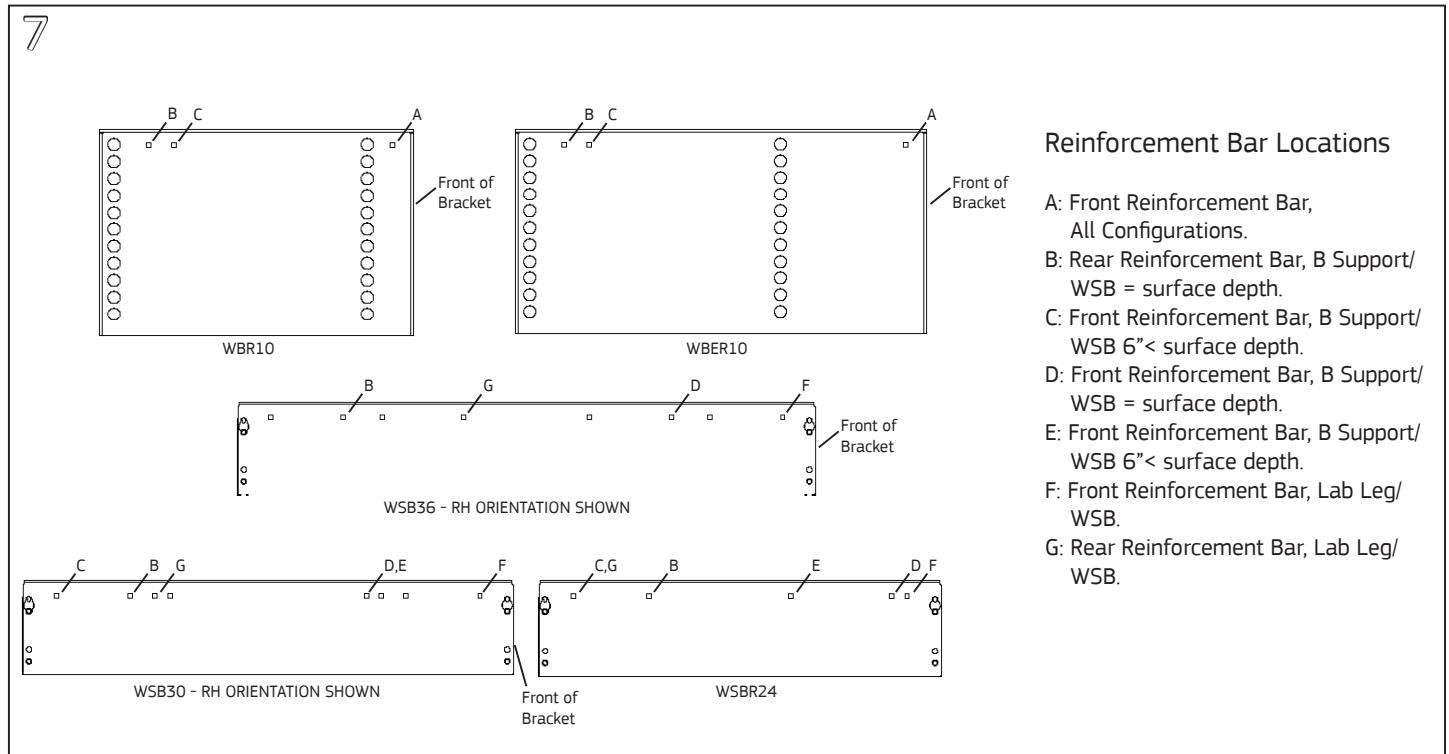

Install Frame-mount Surface Supports (WSB) and/or B Supports (WB, WBE) per product installation instructions. Based on the diagrams above, identify the front and rear Reinforcement Bar locations.

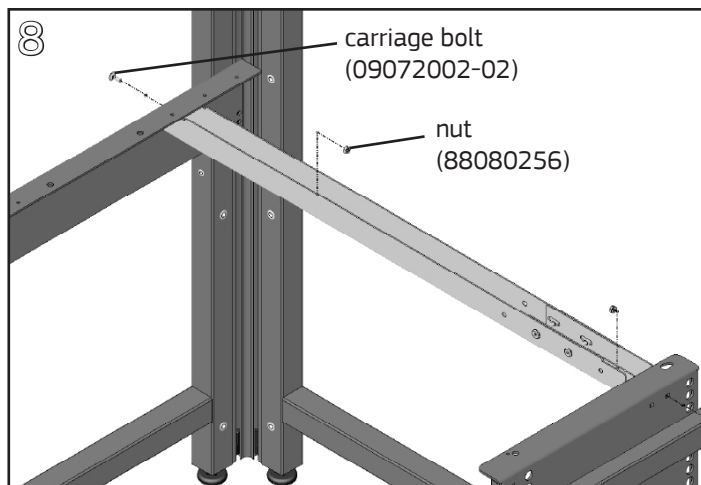

Insert one of the Reinforcement Bar assemblies in the rear position between the surface supports, bringing the bar up from below to clear the bracket flanges. Insert  $\frac{1}{4}$ -20x $\frac{3}{4}$ " carriage bolt into the square holes in the sides of the Frame-mount Surface Supports/B Supports and fasten each with a nut. Tighten the nuts with a  $\frac{7}{16}$ " Nut Driver.

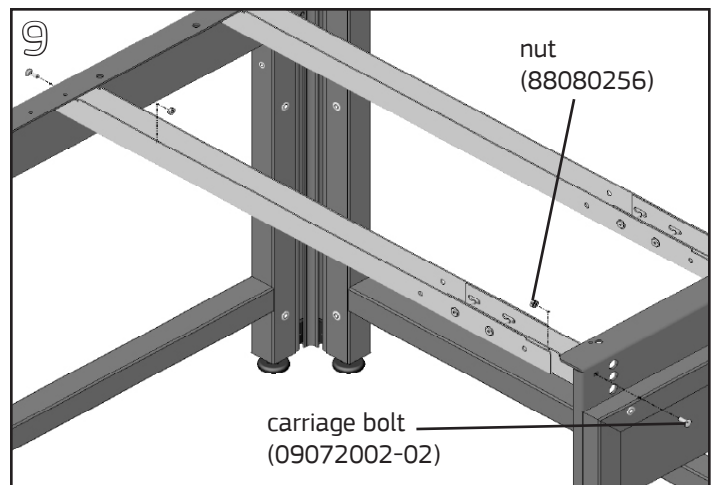

Repeat step 8 with the other Reinforcement Bar assembly at the front position per the diagrams in step 7. Note: Depending on the front bar position, it may be necessary to insert the carriage bolt into the square hole in the Frame-mount Surface Support before fully tightening this bracket to the clip.