

Lab Height B Support Bracket

Product Numbers

- LUSBx
- LUSBEx

Hardware Pack: LUSBHP (p/n 10060705-01)

Required Tools

- 1/4" Allen Wrench or Hex Bit
- #2 Phillips Bit
- Cordless Drill/Driver

WARNING: Do not tighten the #10-12 surface screws more than 25 in-lbs. in laminated surfaces or 40 in-lbs. in phenolic surfaces.

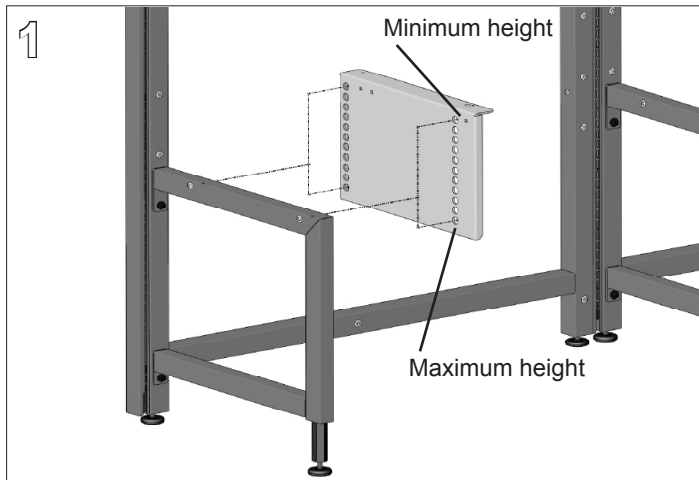

Determine the required surface height. The top set of holes in the side of the Lab Height B Support Bracket will locate the top of the bracket 26-1/8" from the floor when mounted on a CLM, or 31-1/8" from the floor when mounted on a CLT. The additional hole locations are spaced in 1" increments for a total height adjustment range of 10".

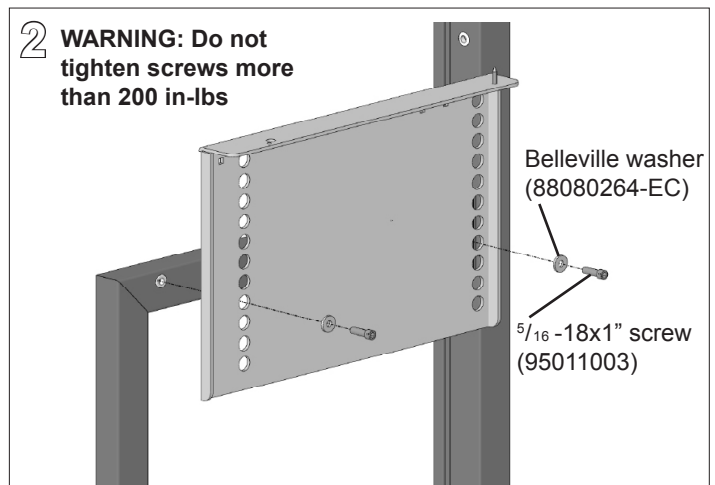

Align the selected height holes in the support with the threaded inserts on the C Leg. Fasten the Lab Height B Support to the C Leg with (2) Belleville washers, placed concave side against the bracket and (2) 5/16-18x1" cap screws using a 1/4" **Allen Wrench/Hex Bit**.

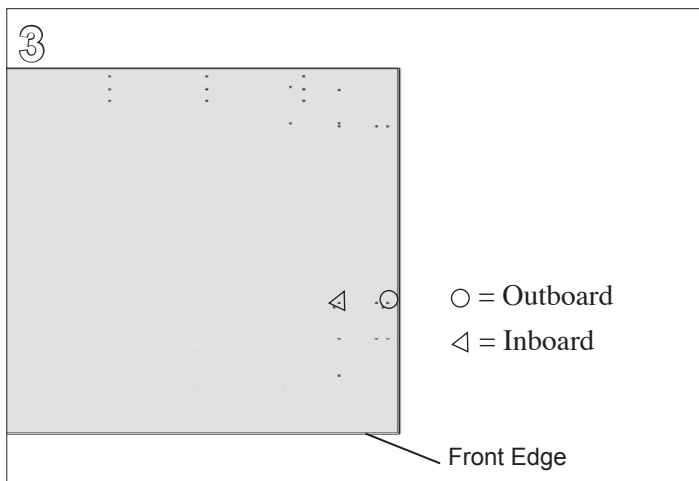

Flip the surface to be mounted to the bracket upside down. Locate the holes as indicated above for the pin. If the C Leg with Lab Height B Support is mounted on the same frame as the surface, use the "Inboard" position. If the C Leg is mounted on a frame adjacent to the surface, use the "Outboard" position.

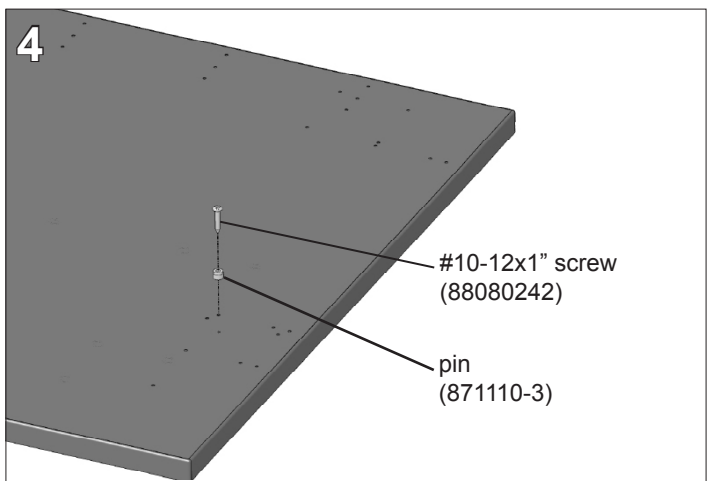

Install a pin at the required location with a #10-12x1" screw using a **cordless drill** and **#2 Phillips bit**. Install additional surface supports and surface mounting hardware as needed on the other end of the surface.

Lab Height B Support Bracket

WARNING: Do not tighten the #10-12 surface screws more than 25 in-lbs. in laminated surfaces or 40 in-lbs. in phenolic surfaces.

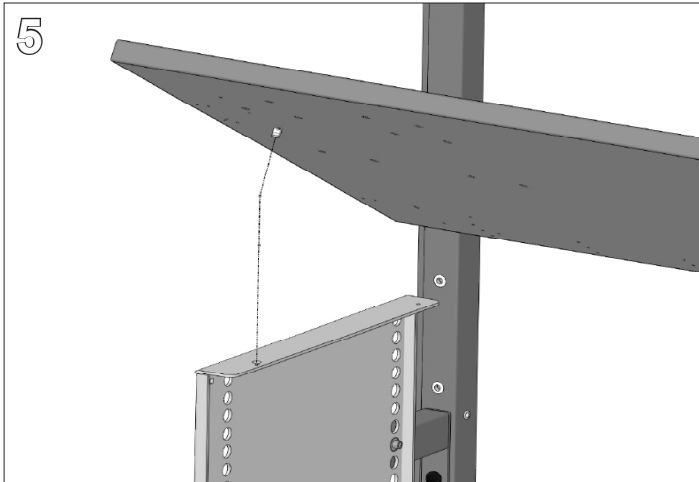

Flip the surface over and align the pin with the large diameter hole near the front of the Lab Height B Support.

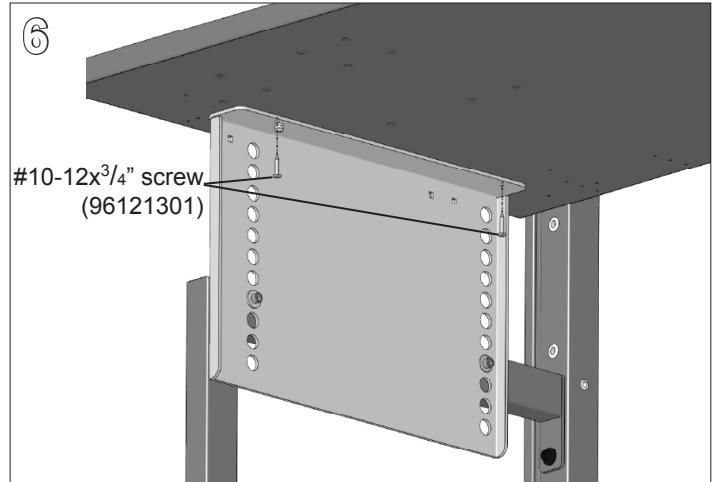

Install a #10-12x³/₄\" screw into each of the remaining holes in the top of the Lab Height B Support using a **cordless drill** and **#2 Phillips bit** (LUSB has two holes, LUSBE has three holes).