

Base Cabinet Front Filler

Product Numbers

- LUFB35Wxx

Hardware Pack: LUFBHP (p/n 09051335-01)

Required Tools

- 1/4" Drive Magnetic Socket with adapter
- Cordless Drill/Driver

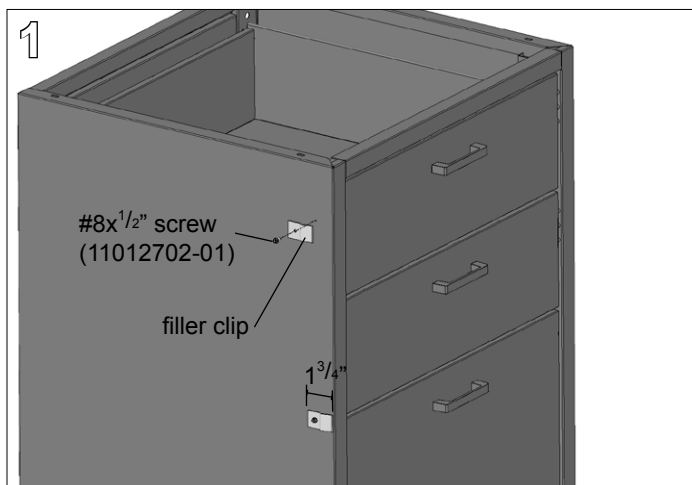

Using a **cordless drill with magnetic socket driver** and **#8x1/2" hex washer head screws**, install three filler clips vertically on the wall side face of the cabinet with a setback of approximately 1-3/4". The cabinets are not predrilled for the clips.

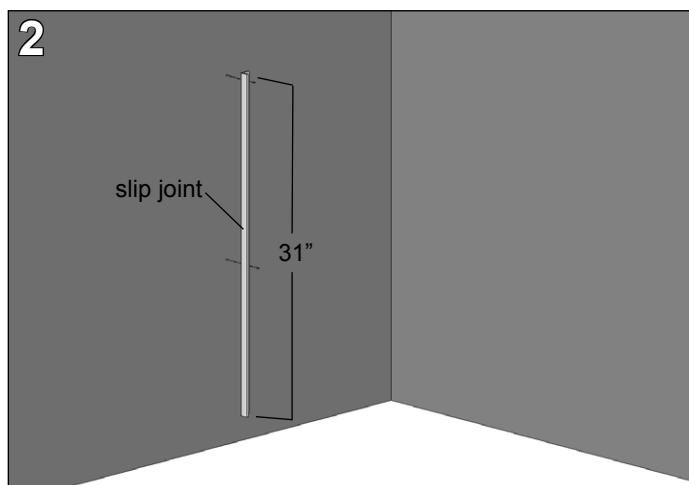

Cut the slip joint to 31" high and fasten to the wall as required. Attachment hardware for the slip joint is not included with the filler kit. Clearance holes in the slip joint are 1/4" diameter.

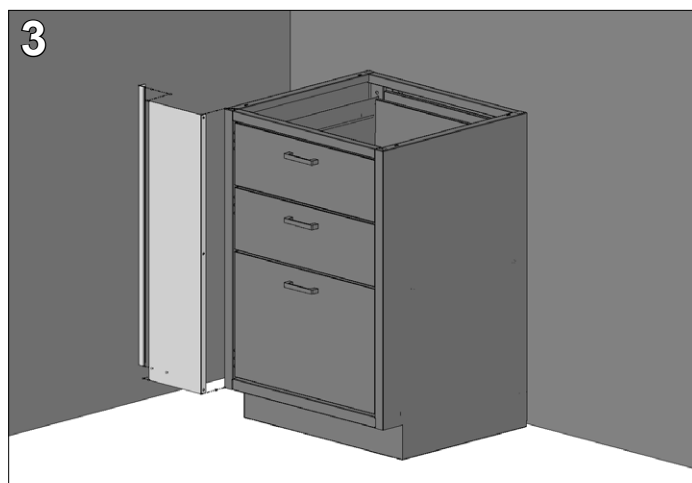

Slide the long flange of the filler into the slip joint and the short flange of the filler into the filler clips on the cabinet. The filler is held in place with a friction fit only, no additional fasteners are needed.

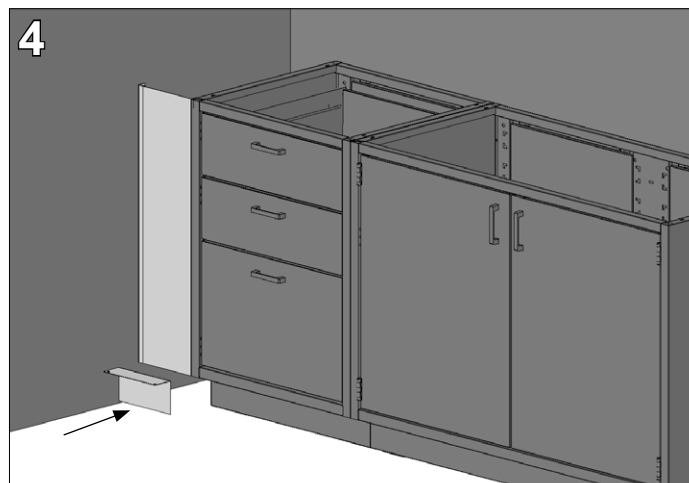

The toe space filler is not provided with a means of attachment. It is suggested that it be placed in the space between the cabinet and wall, and adhered using either epoxy glue, pop rivets, or other fastening method.