

## Frame Spine

### Product Numbers

- FSxx

Hardware Pack: FSHP (p/n 96082803)

### Required Tools

- 1/4" Allen Wrench or 1/4" Hex Bit with driver

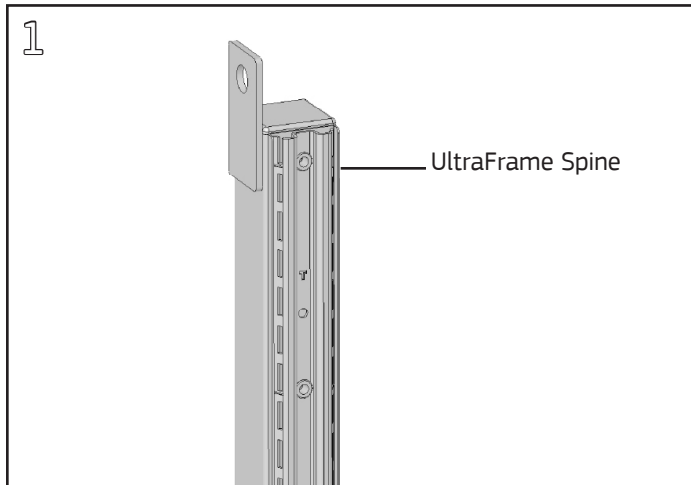

Identify top end of Frame Spine by locating the small "T" cut through the hanger frame on each frame spine half. Orient this end up.

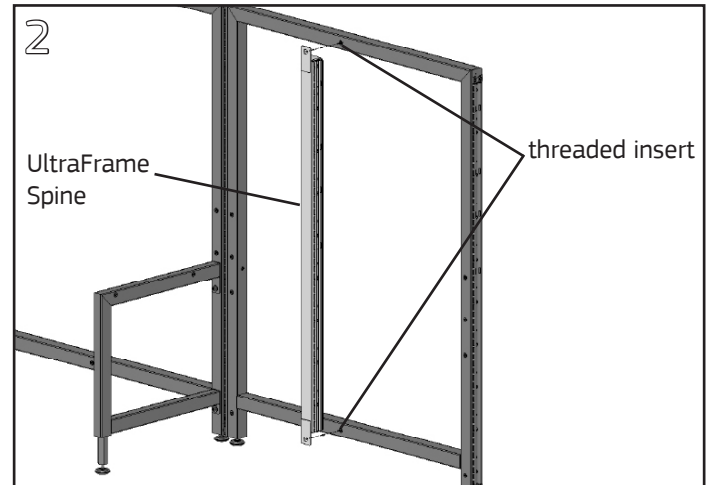

Align the hole in the top and bottom tab of one half of the Frame Spine with the threaded inserts in the top and bottom of the UltraFrame. Orient the hanger frame slots of the frame spine on the right-hand side of the threaded inserts of the UltraFrame.

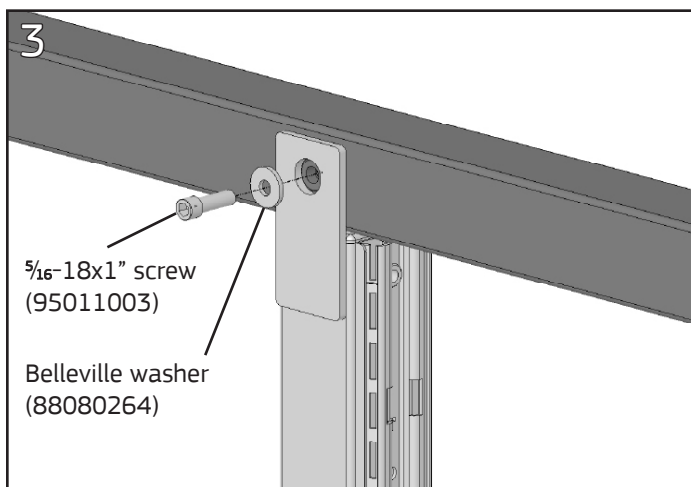

Fasten spine to frame with a Belleville washer, placed concave side against the tab, and a 5/16-18x1" cap screw using a 1/4" Allen Wrench/hex bit at the top and bottom of the Frame Spine tabs.

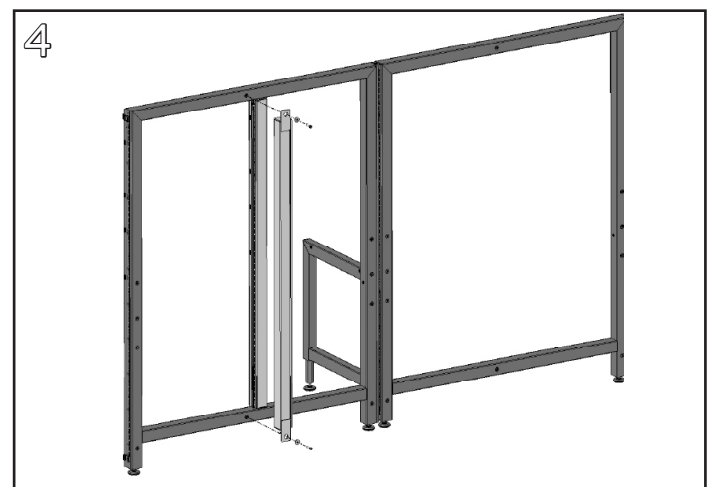

Repeat with the other Frame Spine half, installing it on the opposite face of the UltraFrame.