

## Air Strip

### Product Numbers

- ASxx

Hardware Pack: HCP3 (p/n 88081901)

### Required Tools

- #2 Phillips Screwdriver

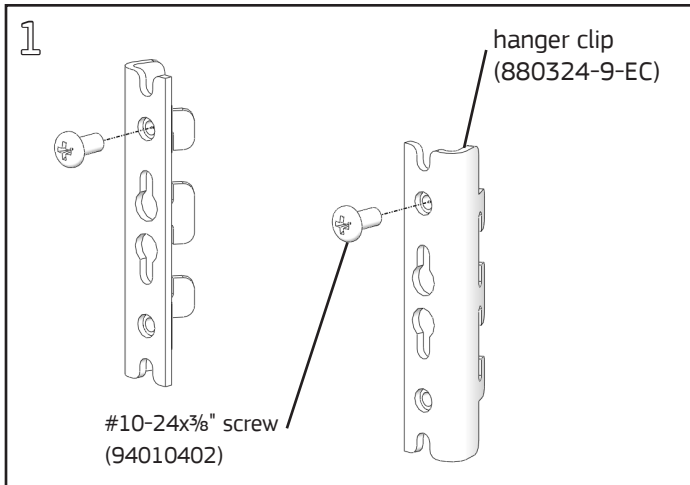

Install a #10-24x $\frac{3}{8}$ " Phillips pan head screw in the top of each hanger clip. Leave a  $\frac{1}{8}$ " gap between the screw and clip.

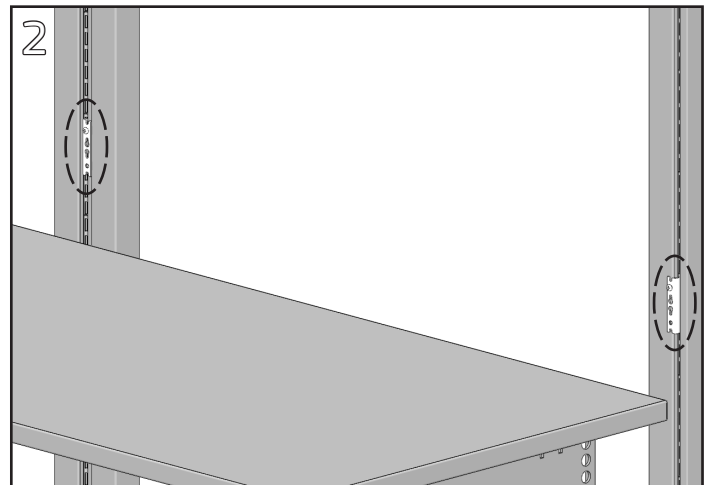

Install a hanger clip on the left and right side of the frame or panel with the screws at the top of each clip.

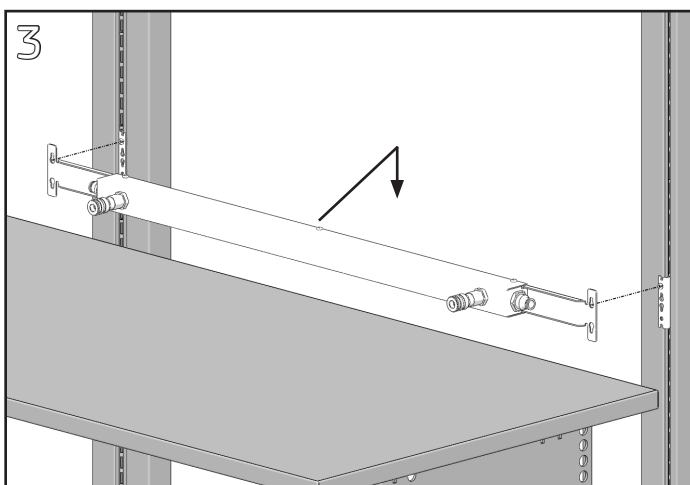

Align the bottom of the top keyslots in the Air Strip with the heads of the hanger clip screws. Slide the Air Strip down over the screws to engage.

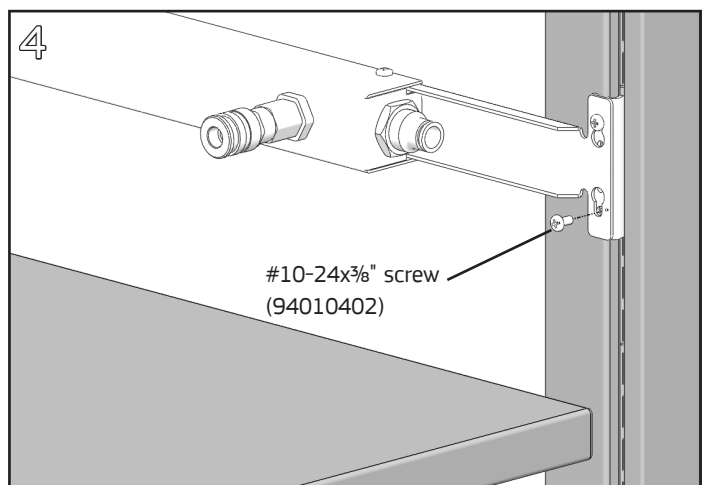

Install an additional #10-24 screw in the bottom keyslot of each hanger clip. Fully tighten all four hanger clip screws with a #2 Phillips screwdriver.