

Surface B Support Bracket

Product Numbers

- WBx
- WBEx

Hardware Pack: WBPHP (p/n 88081609)

WARNING: Do not tighten #10-12 surface screws more than 25 in-lbs. in laminated surfaces or 40 in-lbs. in phenolic surfaces.

Required Tools

- ¼" Allen Wrench or Hex Bit
- #2 Phillips Bit
- Cordless Drill/Driver

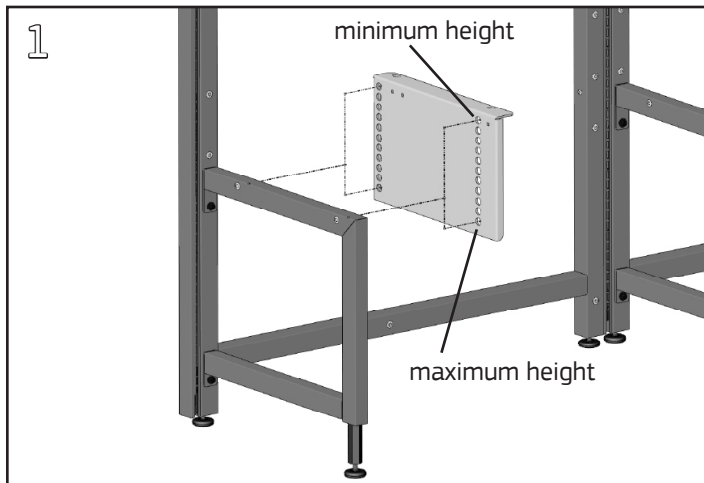

Determine the required surface height. The top set of holes in the side of the Surface B Support Bracket will locate the top of the bracket 25⁷/₈" from the floor when mounted on a CLM, or 30⁷/₈" from the floor when mounted on a CLT. Additional hole locations are spaced in 1" increments for a total height adjustment range of 10".

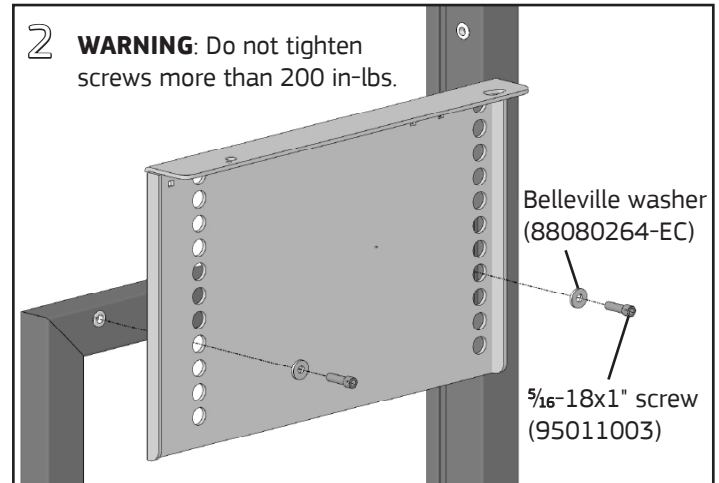

Align the selected height holes in the support with the threaded inserts on C Leg. Fasten Surface B Support to the C Leg with (2) Belleville washers placed concave side against the Surface B Support Bracket and (2) 5/16-18x1" cap screws using a ¼" **Allen Wrench/Hex Bit**.

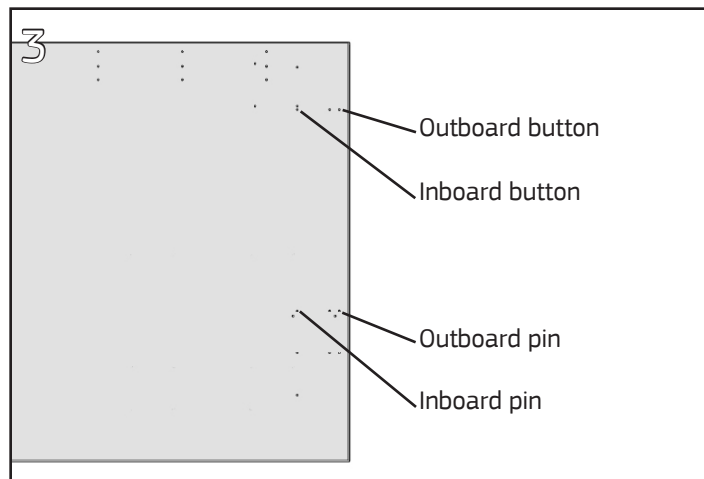

Flip the surface to be mounted to the bracket upside down. Locate holes as indicated above for the pin and button. If the C Leg with Surface B Support is mounted on the same frame as the surface, use the "Inboard" position. If C Leg is mounted on a frame adjacent to the surface, use the "Outboard" position.

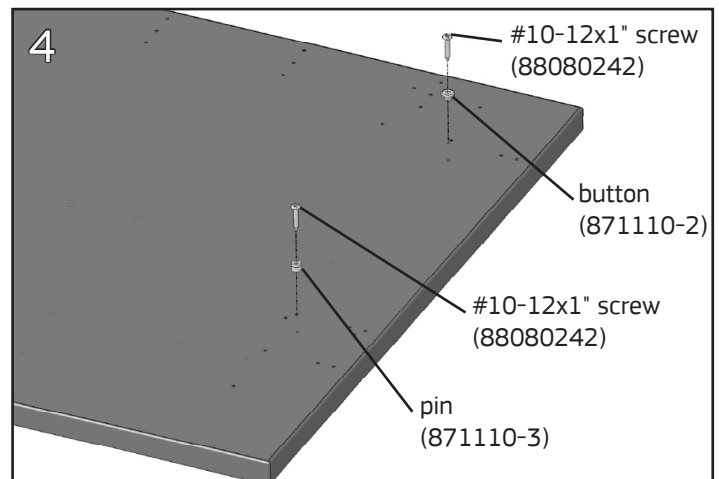

Install each pin and button at the required location with a #10-12x1" screw using a **cordless drill and #2 Phillips bit**. Tighten the pin fully, but leave an 1/8" gap between surface and underside of button. Install additional surface supports and surface mounting hardware as needed on the other end of the surface.

Surface B Support Bracket

WARNING: Do not tighten #10-12 surface screws more than 25 in-lbs. in laminated surfaces or 40 in-lbs. in phenolic surfaces.

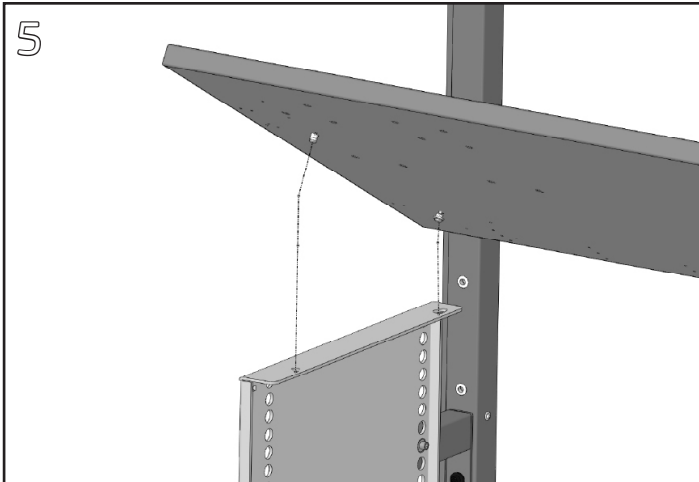

Flip the surface over and align the button with the large end of the keyslot near the back of the Surface B Support. Push the surface back while rotating down so the pin aligns with the large diameter hole near the front of the Surface B Support.

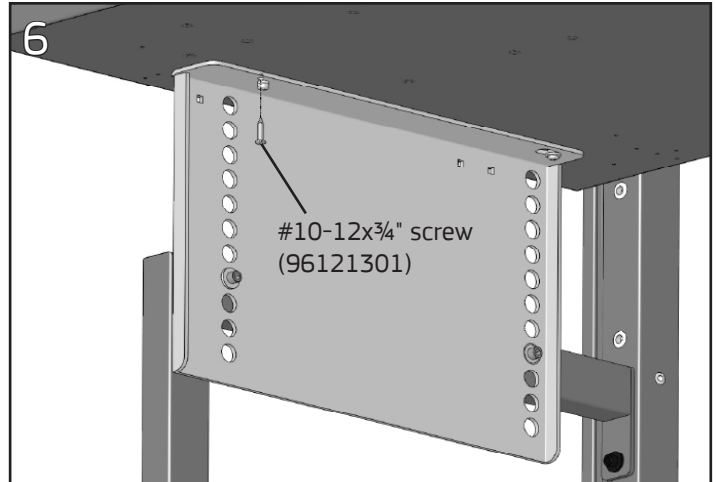

Fully tighten the button and install a #10-12x $\frac{3}{4}$ " screw into each of the remaining holes in the top of the Surface B Support (WB has one hole, WBE has two holes).