

Surface Cantilever Supports

Product Numbers

- WSLxx
- WSRxx

Required Tools

- #2 Phillips Screwdriver and/or #2 Phillips Bit
- Cordless Drill/Driver

Hardware Pack: WSPHP (p/n 88082502)

WARNING: Do not tighten #10-12 surface screws more than 25 in-lbs. in laminated surfaces or 40 in-lbs. in phenolic surfaces.

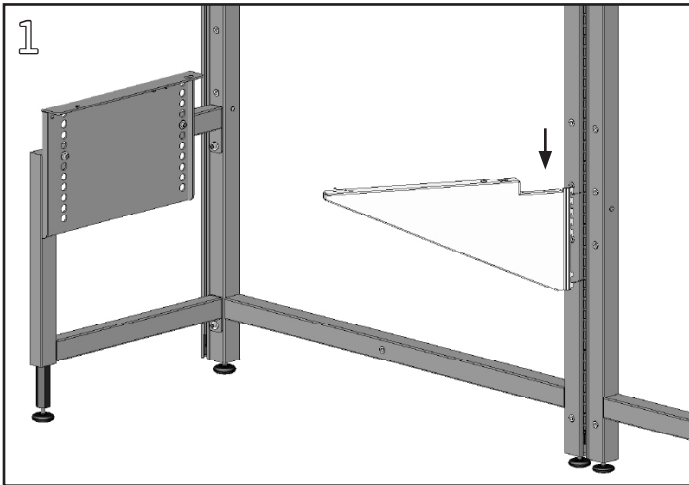

Rotate the Cantilever Support at an angle inboard of the frame. Align with hanger frame slots in the side of the frame at appropriate height. Push the support down to securely seat in the slots. Surfaces 72" and wider require an additional support at frame joint.

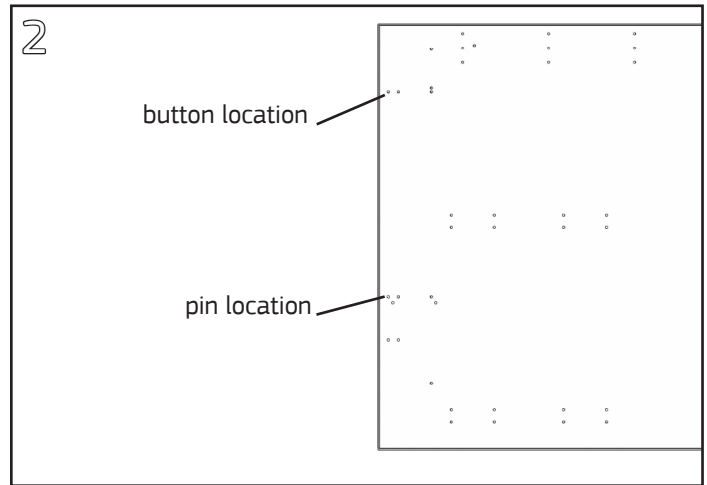

Flip the surface to be mounted to the bracket upside down. Locate the holes as indicated above for the pin and button.

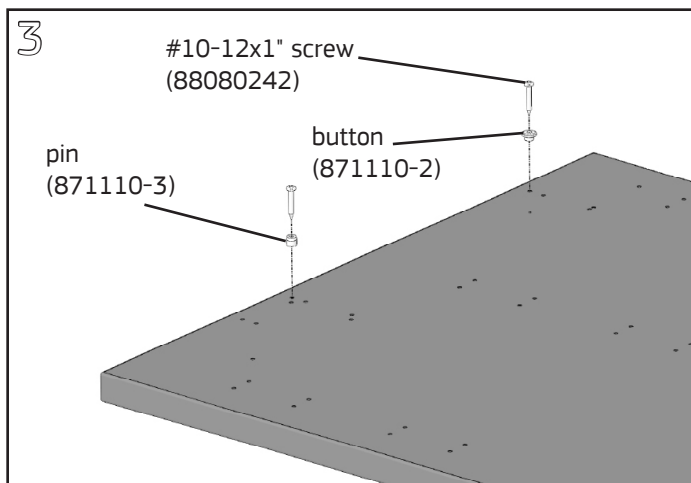

Install each pin and button at the required location with a #10-12x1" screw using a **cordless drill** and a **#2 Phillips bit**. Tighten the pin fully, but leave a 1/8" gap between the surface and underside of the button. Install additional surface supports and surface mounting hardware as needed on the other end of the surface.

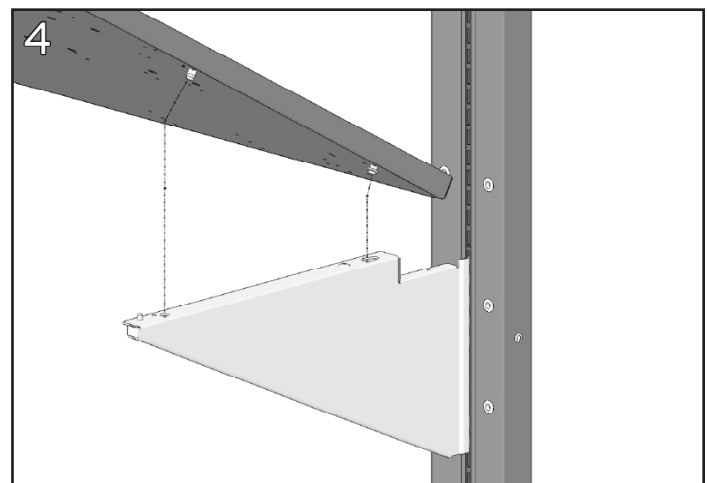

Flip the surface over and align the button with the large end of the keyslot near the back of the Cantilever Support. Push the surface back while rotating down so that the pin aligns with the large diameter hole near the front of the support.

Surface Cantilever Supports

WARNING: Do not tighten #10-12 surface screws more than 25 in-lbs. in laminated surfaces or 40 in-lbs. in phenolic surfaces.

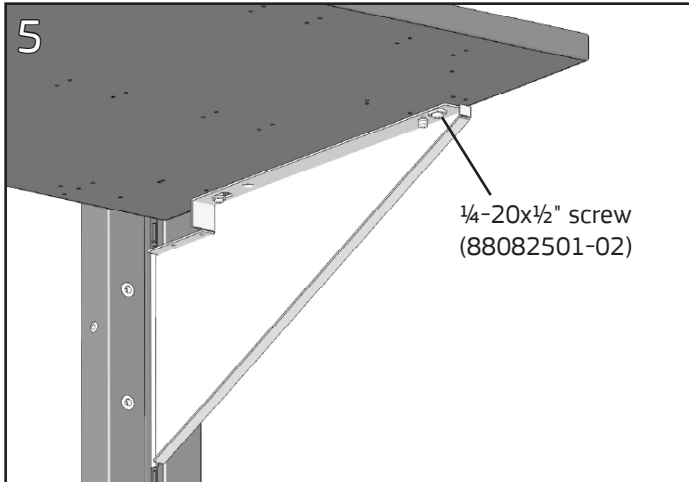

Fully tighten the button. Level the surface by adjusting the 1/4-20x1/2" Phillips pan head screw which has been preinstalled near the front of the Cantilever Support.

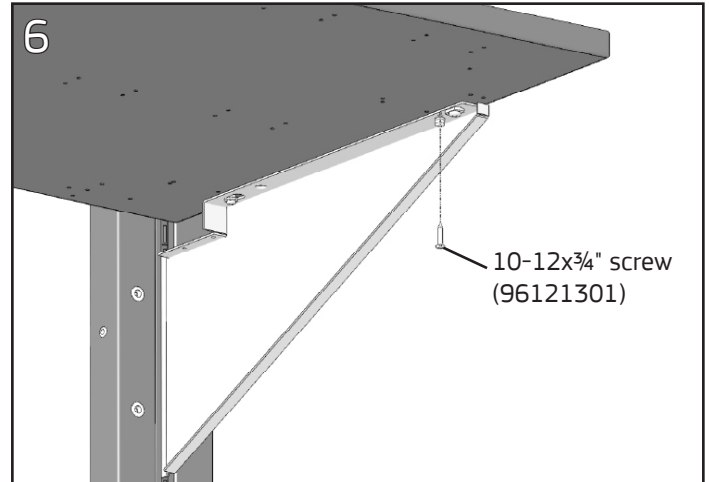

Install a #10-12x3/4" screw in the hole next to the pin to securely anchor the surface to the support.