

Positionable Height Adjustable Bases

Product Numbers

- ESPTC... ESPTG...
- TBPTC... TBPTG...
- WTPTC... WTPTG...

Required Tools

- $\frac{3}{16}$ " Allen Wrench

Hardware Pack: ETWPHP (p/n 93082504)

Notes:

- For commercial use only.
- This product is shipped fully assembled and has no user serviceable parts. Servicing is to be performed by an authorized service representative only.
- Work surfaces are composed of a particleboard core when used with stainless steel or laminate. Surfaces may also be composed of phenolic or epoxy resin. Minimum thickness is one inch.
- Maximum surface width: 24" greater than width of base.
- Maximum surface depth: 48" for 36" deep base; 36" for 30" deep base; 30" for 24" deep base.

WARNING: Do not tighten the #10-12 surface screws more than 25 in-lbs. in laminated surfaces or 40 in-lbs. in phenolic surfaces.

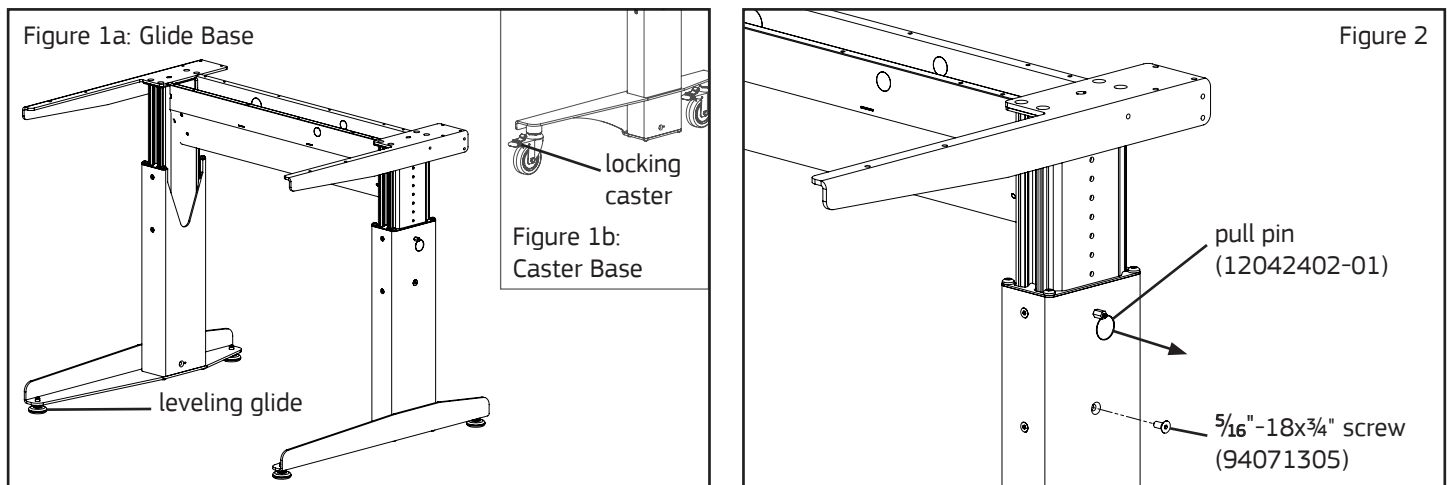

1. Place base in desired location. For glide bases, level the base by adjusting the four glides on the bottom of the feet (Figure 1a). For caster bases, apply the caster locks (Figure 1b) when base is in use.
2. To adjust height, remove the $\frac{5}{16}$ "-18x $\frac{3}{4}$ " socket flathead screw using a $\frac{3}{16}$ " Allen wrench (Figure 2).
3. While supporting the weight of the top of the base, pull out ring of pull pin and adjust leg up or down in one inch increments to desired position. Let go of pull ring so pull pin re-engages in inner leg and align countersunk hole in outer leg with a tapped hole in inner leg. Reinsert socket flathead screw to 110 in-lbs. with a $\frac{3}{16}$ " Allen wrench (Figure 2).