

Electrical Distributor Inset-Mount Cover, Corner

Product Numbers

- EDCN2

Hardware Pack: EDCN2 (p/n 12022502-01)

Required Tools:

- #2 Phillips Screwdriver
- 1/4" Wrench

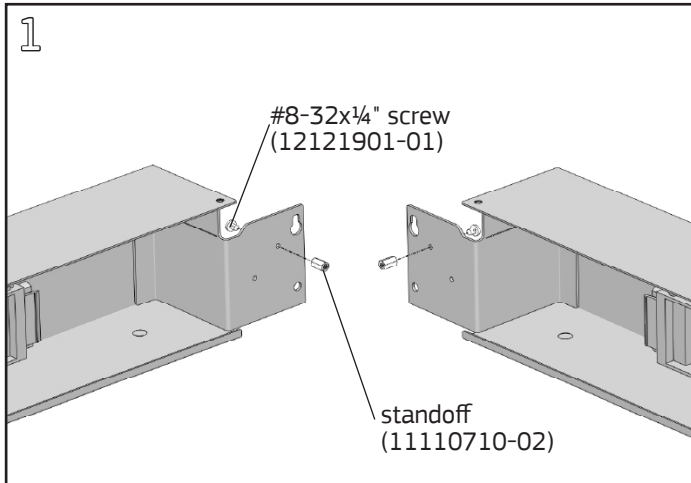

Before installing the Electrical Distributors on the frames, install a #8-32x1/4" Phillips panhead screw in the upper tapped hole on the distributor base end near the corner connection. Fasten a hex standoff to the end of each screw and tighten with a 1/4" wrench and #2 Phillips screwdriver.

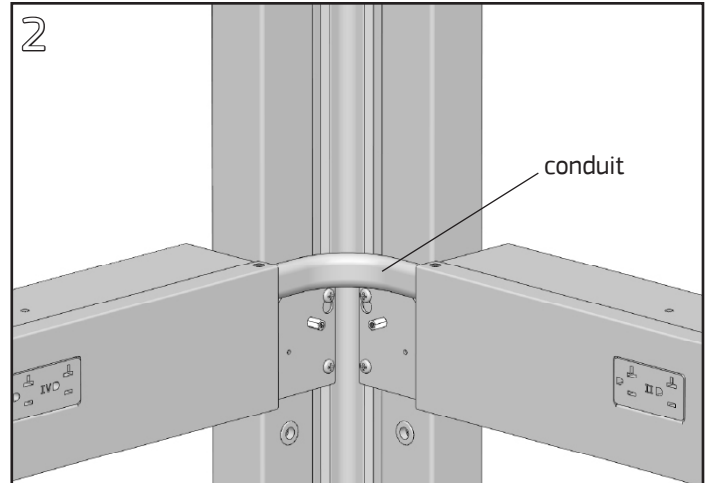

Install Electrical Distributors and Jumper Cable per individual product installation instructions. Route the Jumper Cable conduit above the Electrical Distributor hanger clips.

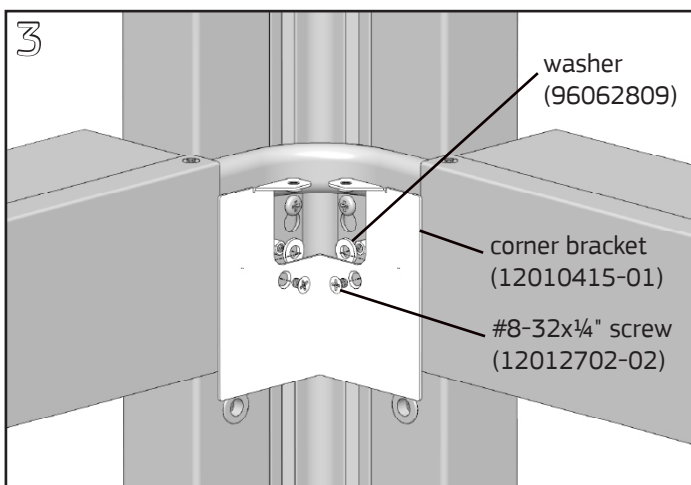

Align the countersunk holes in the corner bracket with the standoffs attached to Electrical Distributors. Insert a #8-32x1/4" Phillips flathead screw through each counter-sunk hole, then a nylon washer, and tighten screws with a #2 Phillips screwdriver.

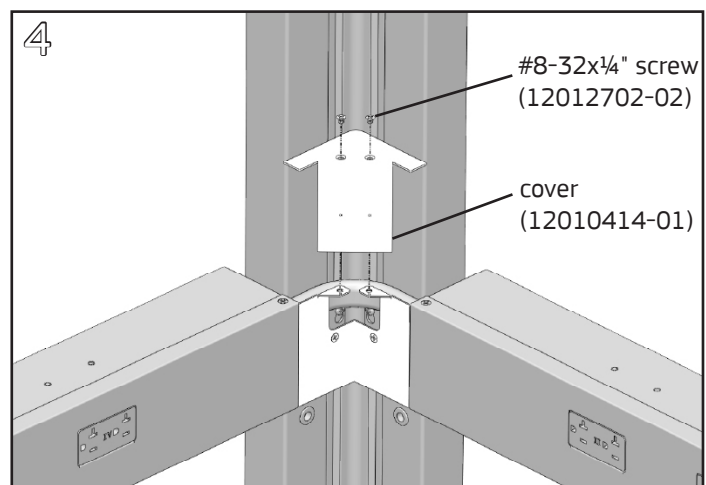

Place the cover on top of the support tabs of the corner bracket. Install a #8-32x1/4" Phillips flathead screw through each countersunk cover hole and tighten with a #2 Phillips screwdriver.