

Electrical Distributor Inset-Mount Cover, Entry

Product Numbers

- EDCN1

Hardware Pack: EDCN1 (p/n 12022501-01)

Required Tools:

- #2 Phillips Screwdriver
- 1/4" Wrench

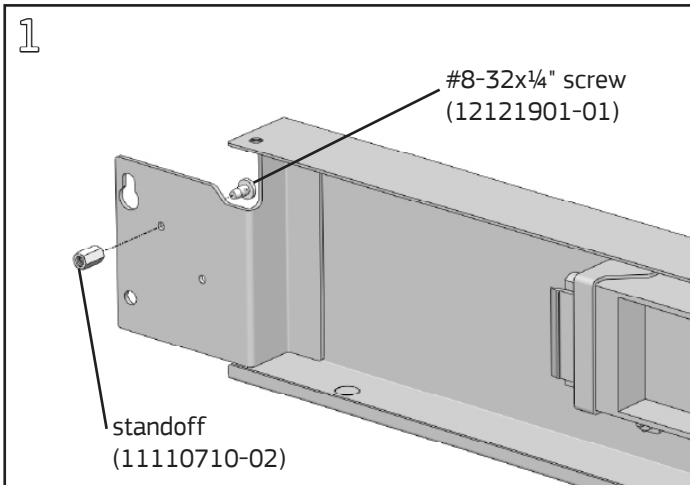

Before installing the Electrical Distributor on a frame, install a #8-32x1/4" Phillips panhead screw in the upper tapped hole on the distributor base end to be installed next to the Vertical Distributor. Fasten a hex standoff to the end of the screw and tighten with a 1/4" wrench and #2 Phillips screwdriver.

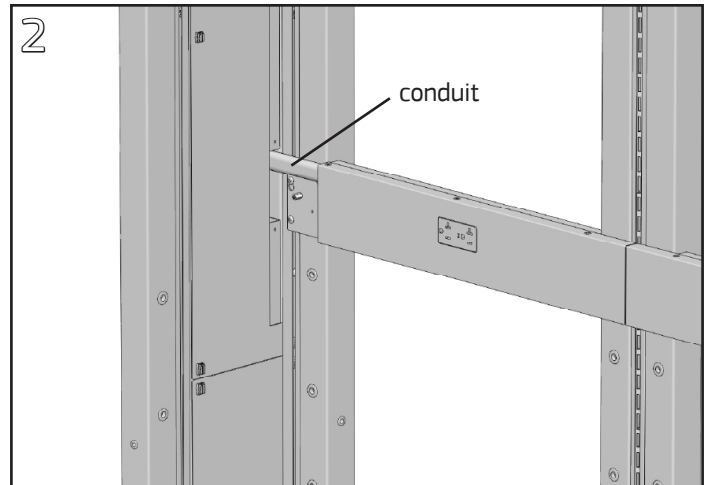

Install Vertical Distributor, Electrical Distributor and Entry Cable per individual product installation instructions. Route the Entry Cable conduit above the Electrical Distributor hanger clip.

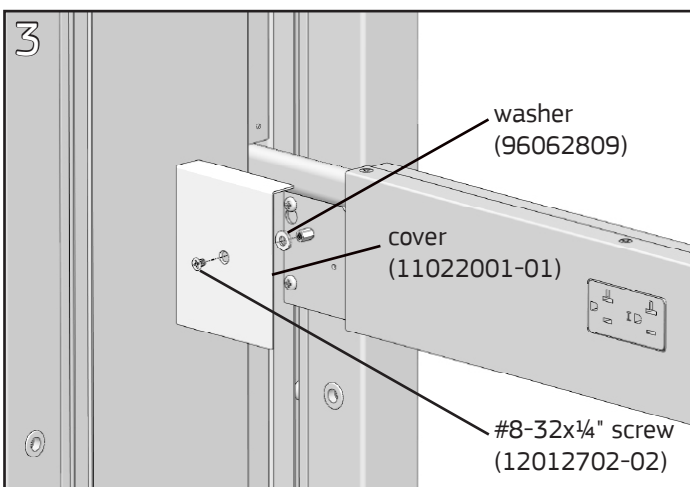

Insert a #8-32x1/4" Phillips flathead screw through the countersunk hole in the cover, then a nylon washer, and align it with the tapped hole in the hex standoff. Tighten screw with a #2 Phillips screwdriver.