

## 4-Legged Table

### Product Numbers

- FLPCxxxx
- FLPGxxxx

**Hardware Pack:** FLPAHP\*\* (p/n 11101805-01-\*\*)   
 FLPBHP (p/n 11101801-02) for black tables   
 FLPZHP (p/n 11101801-01) for all other colors

### Required Tools

- $\frac{3}{16}$ " Hex Bit (included) or Allen Wrench
- Cordless Drill with  $\frac{1}{8}$ " or  $\frac{11}{64}$ " Bit
- #2 Phillips Head Screw Driver or Bit

**WARNING:** Do not tighten the #10-12 surface screws more than 25-in-lbs. in laminated surfaces or 40-in-lbs. in phenolic surfaces. Drill  $\frac{1}{8}$ " diameter pilot holes for laminated surfaces or  $\frac{11}{64}$ " diameter pilot holes for phenolic surfaces.

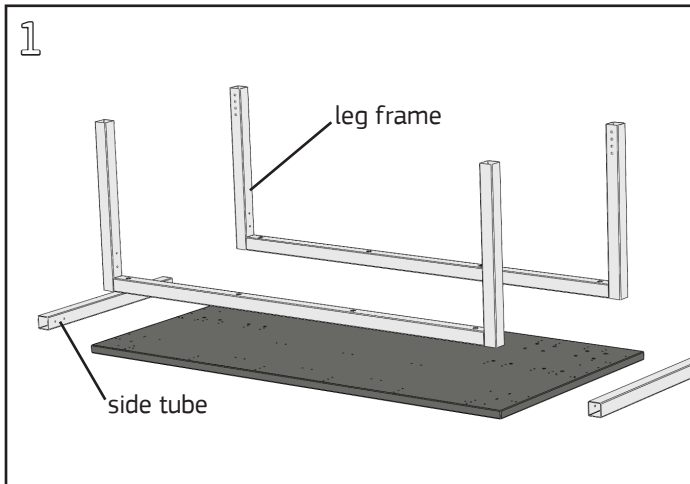

Begin with the surface upside down on the floor. Arrange the legs and side tubes so they are centered on the surface with all of the fastener holes facing inward.

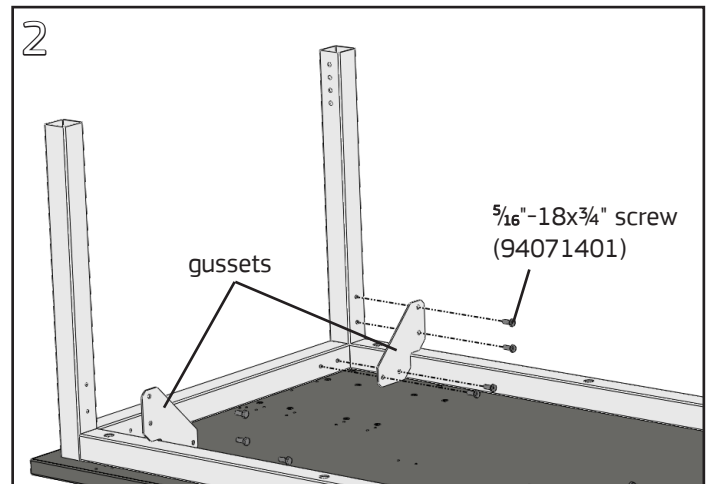

Fasten gussets between side tubes and leg frames. Leave loose by threading the  $\frac{5}{16}$ "-18x $\frac{3}{4}$ " socket button head screw only a few turns. Once all screws are in place go back and fully tighten with a  $\frac{3}{16}$ " hex bit and driver.

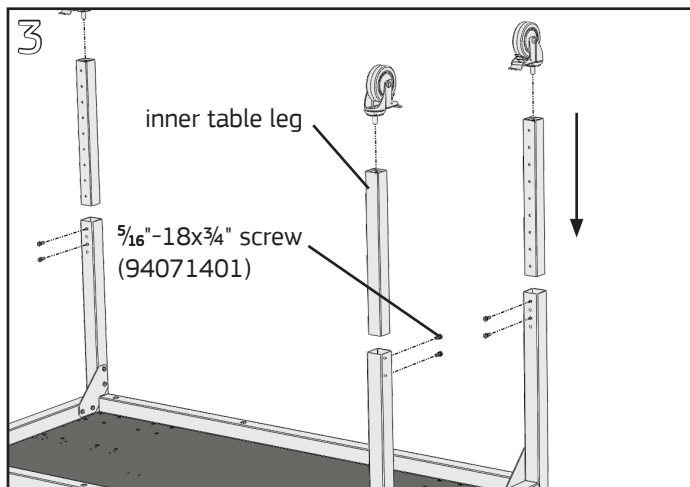

Attach glides or casters to the inner legs through the nut plate. Attach adjustable legs to the leg frames with  $\frac{5}{16}$ "-18x $\frac{3}{4}$ " socket button head screws at desired location.

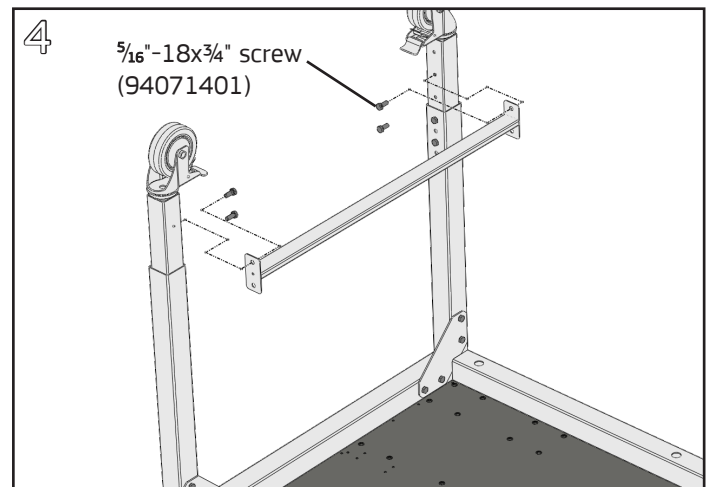

Attach support bars with  $\frac{5}{16}$ "-18x $\frac{3}{4}$ " socket button head screws at desired location.

## 4-Legged Table

**WARNING:** Do not tighten the #10-12 surface screws more than 25-in-lbs. in laminated surfaces or 40-in-lbs. in phenolic surfaces. Drill  $\frac{1}{8}$ " diameter pilot holes for laminated surfaces or  $\frac{11}{64}$ " diameter pilot holes for phenolic surfaces.

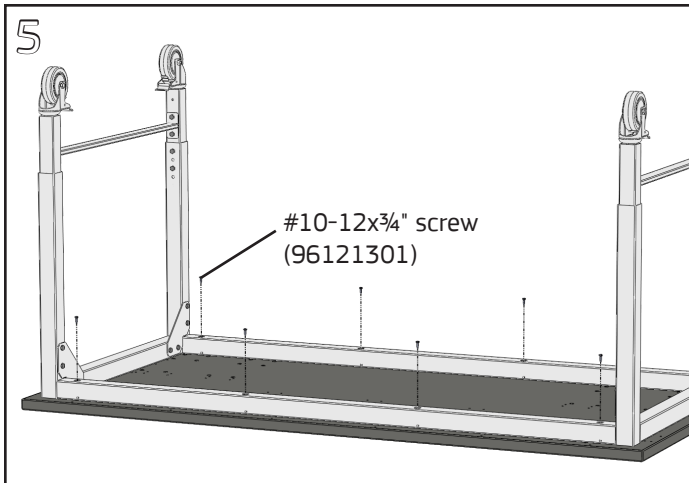

Mark surface mounting holes with a pencil through the table frame and drill pilot holes with  $\frac{1}{8}$ " drill bit;  $\frac{1}{2}$ " depth recommended. Fasten the table frame to the surface with the #10-12x $\frac{3}{4}$ " Phillips head screws. With help, flip the table right side up.