

### Lab Leg Filler

**Product Numbers**

- LULF35Exx

**Hardware Pack:** none

**Required Tools**

- 5mm Allen Wrench

**Note:** Do not attach the surface to the Lab Leg before installing the Lab Leg Fillers.

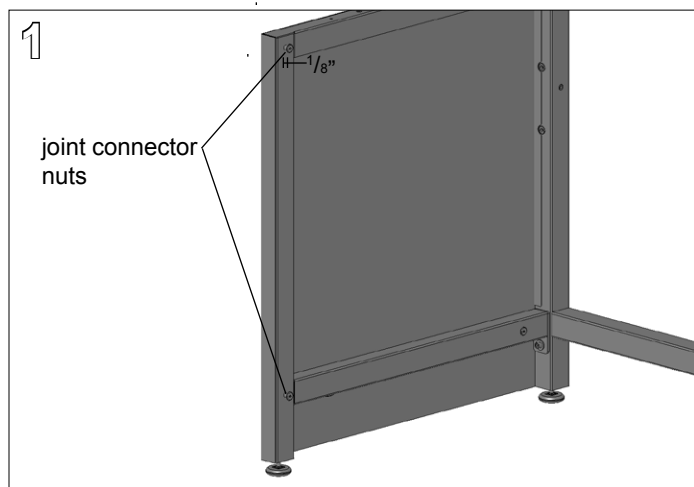

Install Lab Leg Panel according to its installation instructions. Leave the two joint connector nuts along the front tube of the Lab Leg loose leaving approximately an 1/8" gap between the leg and nut.

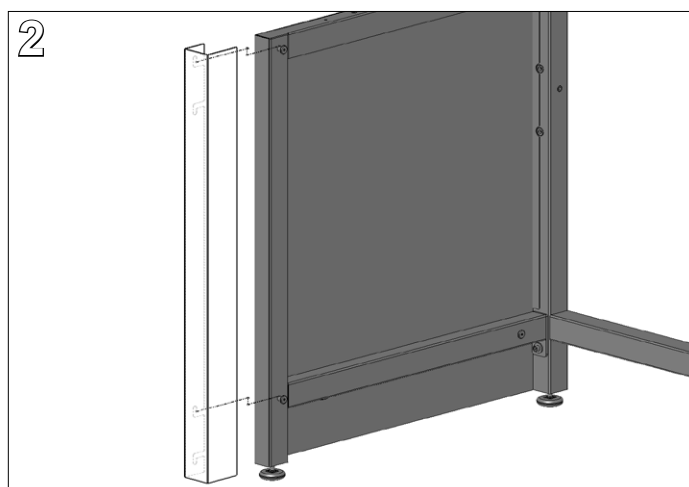

With the slotted side of the Lab Leg Filler against the leg, slide the filler onto the leg nuts at the top and second from bottom dog leg slots. Tighten the Lab Leg joint connector nut fully with a **5mm Allen Wrench**.

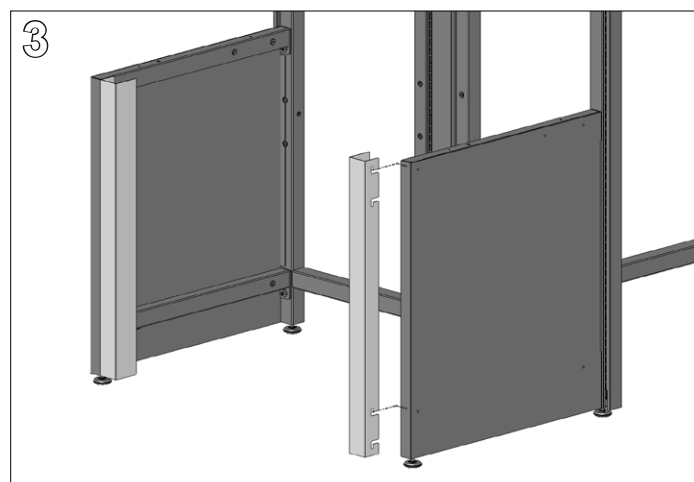

If using a filler larger than 1" wide, repeat steps 1 and 2 on the opposite hand Lab Leg.

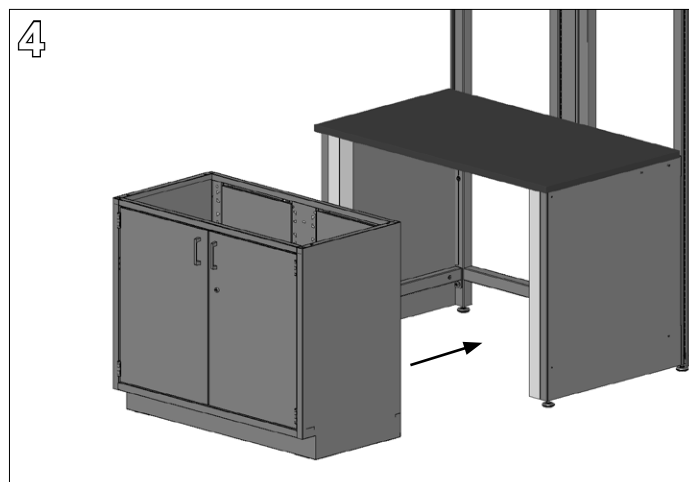

Install work surface according to Lab Leg installation instructions. Slide Base Cabinet into position.