

Rear Base Cabinet Fillers

Product Numbers

- LUFB35Dxx

Hardware Pack: LUFBHP (p/n 09051335-01)

Required Tools

- 1/4" Drive Magnetic Socket with adapter
- Cordless Drill/Driver

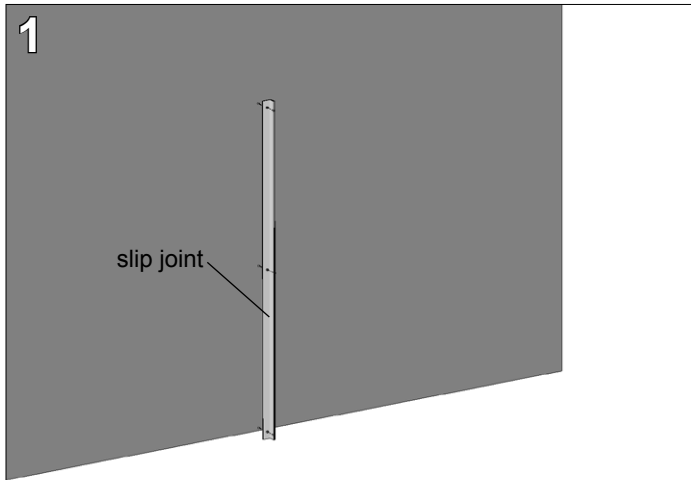

Fasten the slip joint to the wall as required. Attachment hardware for the slip joint is not included with the filler kit. Clearance holes in the slip joint are 1/4" diameter.

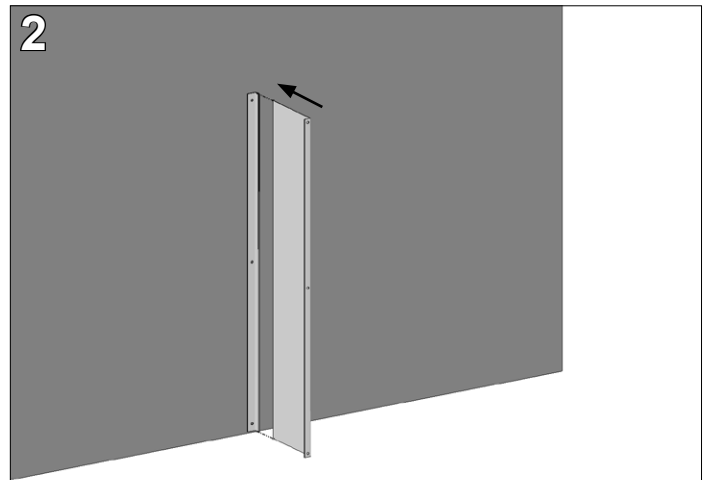

Slide the long flange of the filler into the slip joint. The filler is held in place with a friction fit only, no additional fasteners are needed.

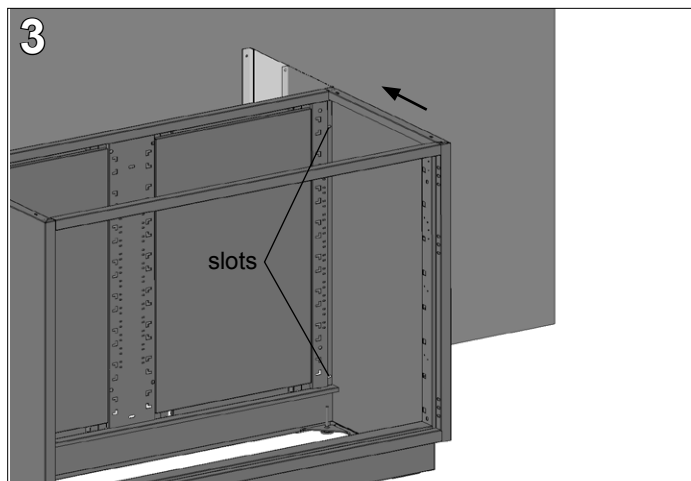

Align the side of the base cabinet with the side of the filler. Locate the horizontal slots near the top and bottom of the inside of the cabinet. Mark these locations on the short flange of the filler. Cabinet shelves and drawers may need to be removed to accomplish this.

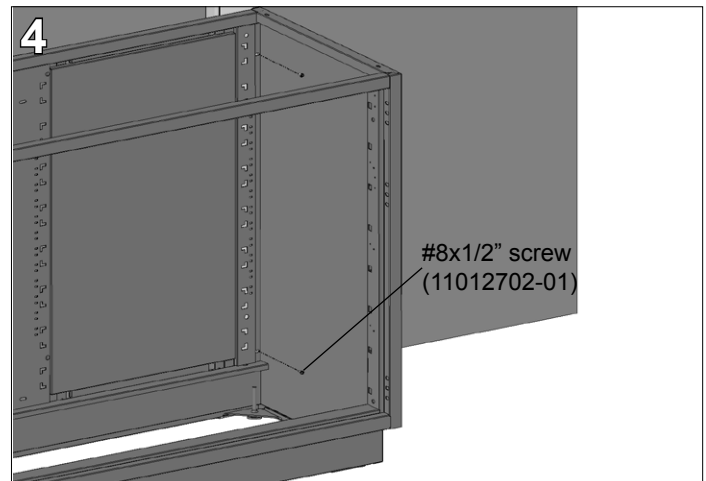

If desired, remove filler and predrill holes. From within the cabinet, using a **cordless drill with magnetic socket driver** and (2) #8x1/2" hex washer head screws, attach the back of the cabinet to the short flange of the filler.