

Ultra and Work Surfaces, ErgoStat/Table Base Mounting

Product Numbers

- UCR, UDR, ULR
- UCS, UDS, ULS
- UDT, ULT
- USC
- SCR, SDR, SLR
- SCS, SDS, SLS
- SMR

Required Tools

- ✂ #2 Philips Bit with Driver or Screwdriver
- ✂ Tape Measure

Hardware Pack: ESTBHP (p/n 93082503)

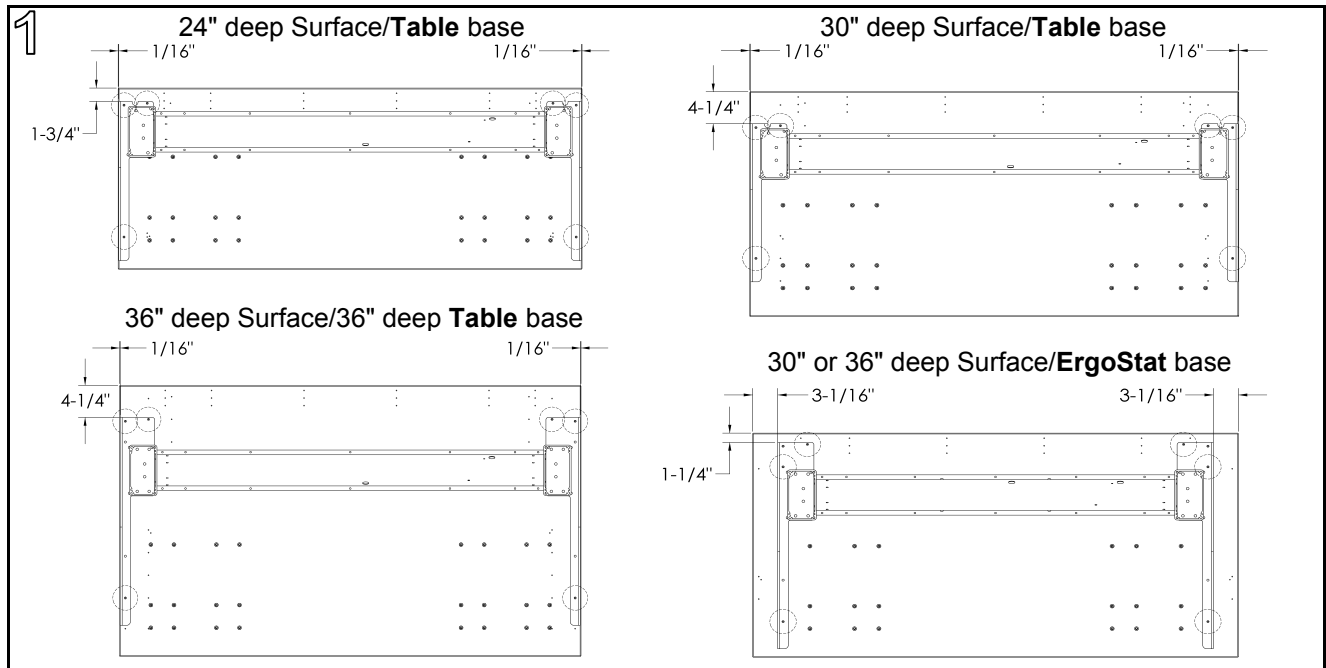

With the surface on the floor upside down if possible, position the brackets according to the dimensions shown above for proper surface/base combination. The dotted circles indicate the holes that will be aligned in the bracket and the surface for installing fasteners

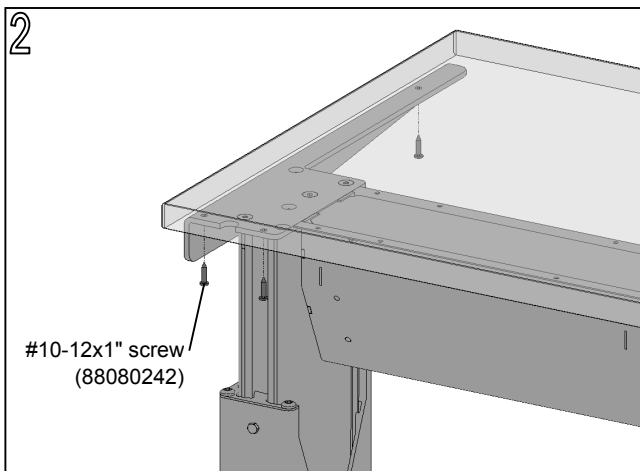

Insert (3) #10-12x1" Panhead screws into the bracket holes and tighten with #2 Philips bit or screwdriver. Repeat on opposite bracket.

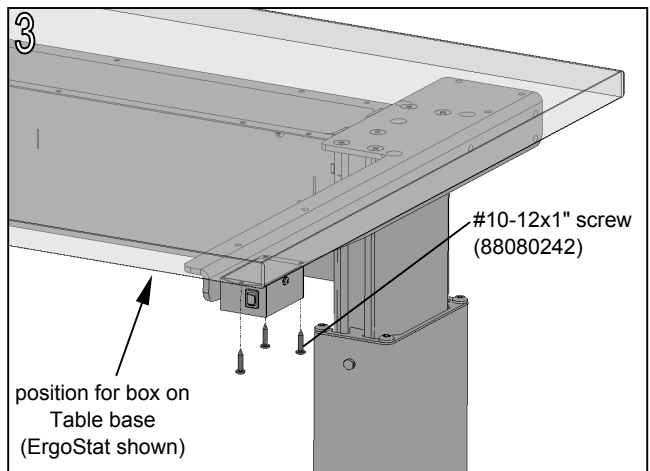

ELECTRIC BASES ONLY - Surfaces do not have predrilled holes for the control box. Position control box and fasten with (3) #10-12x1" Panhead screws.