

Roll-Out Shelf, Medium Duty

Product Numbers

- RSM2424
- RSM2430
- RSM2436
- RSM2448

Required Tools

- ✂ 11/32 Nut Driver
- ✂ #2 Phillips Screwdriver

Hardware Pack: RSMHP (08022802-01)

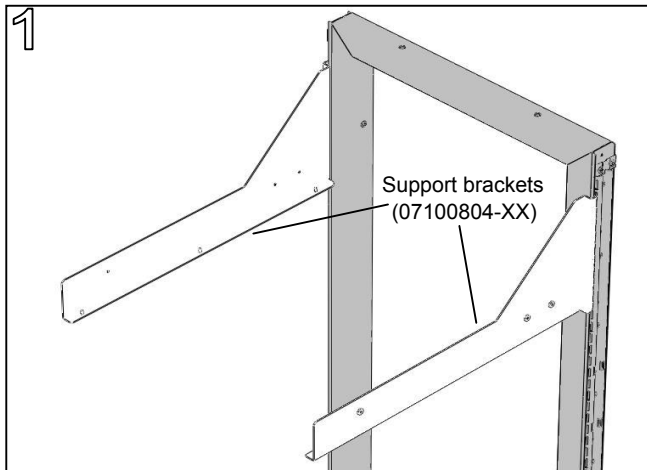

Install two support brackets at same height, one on the left and one on the right of the front face of the frame.

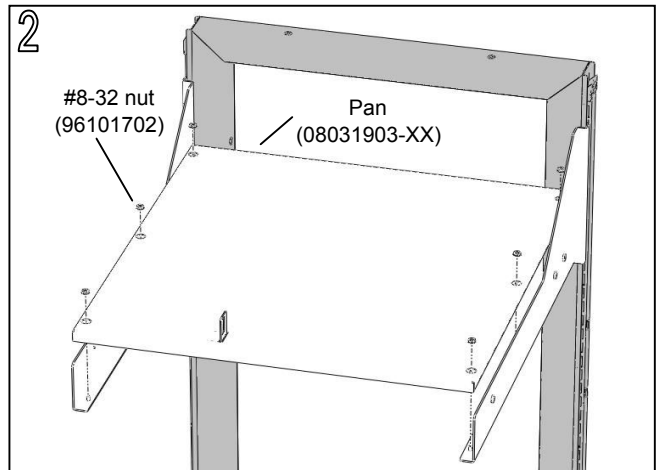

Place pan on support brackets aligning holes in pan with the threaded studs on the brackets. After pan is in place, start all (6) nuts by hand and tighten with **11/32 nut driver**.

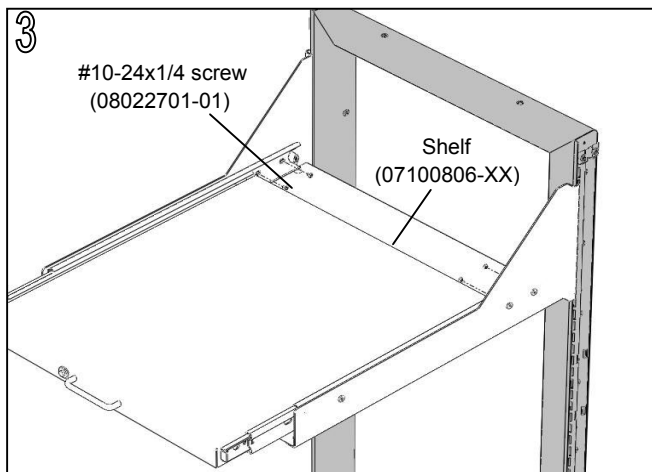

Place shelf/slide assembly partially on pan. Extend slides to expose the outer channel of slides. Align back two slots of slide with the two weldnuts on the rear of brackets. Insert #10-24x1/4 screws (2 per side) using a **#2 Phillips screwdriver**. Do not fully tighten these screws.

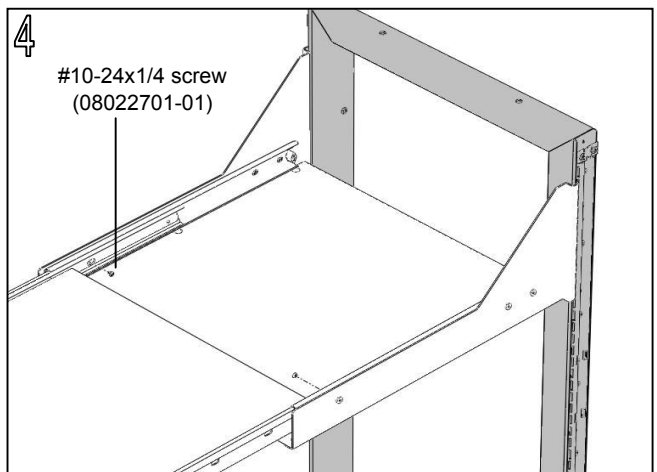

Fully extend the shelf. Align front holes in slides with front weldnuts on brackets. Insert #10-24x1/4 screw (1 per side) using a **#2 Phillips screwdriver**. Fully tighten these screws. Then fully tighten the (4) screws placed in step 3.

SYMBIOTE® Technical Furniture

www.symbiote.com 300 N. Centennial Street Zeeland, MI 49464 ph:(616)772-1790 fx:(616)772-1797