

Storage Cabinet Assemblies

Product Numbers

- SCA

Hardware Pack: included in box

Required Tools

- #2 Phillips Screwdriver or #2 Phillips Bit
- Cordless Drill/Driver

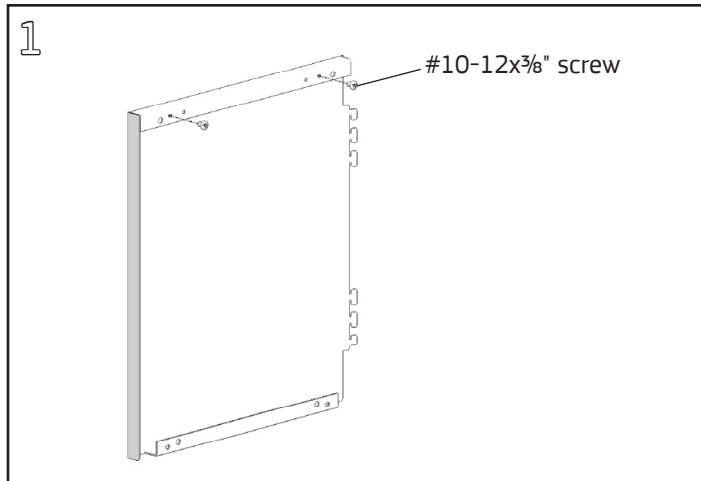

The top of each end panel has a set of three front and three rear holes. Install a #10-12x $\frac{3}{8}$ " Phillips pan head screw in the center hole of each set, leaving a $\frac{1}{8}$ " gap between the panel and underside of the screw head, on both the left- and right-hand end panel.

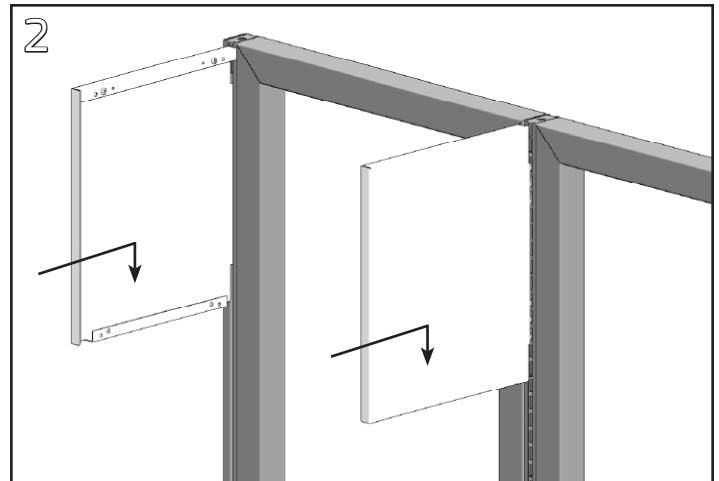

Install end panels on the left and right sides of the frame/panel at the desired height. Ensure the panels are firmly seated in the hanger frame slots.

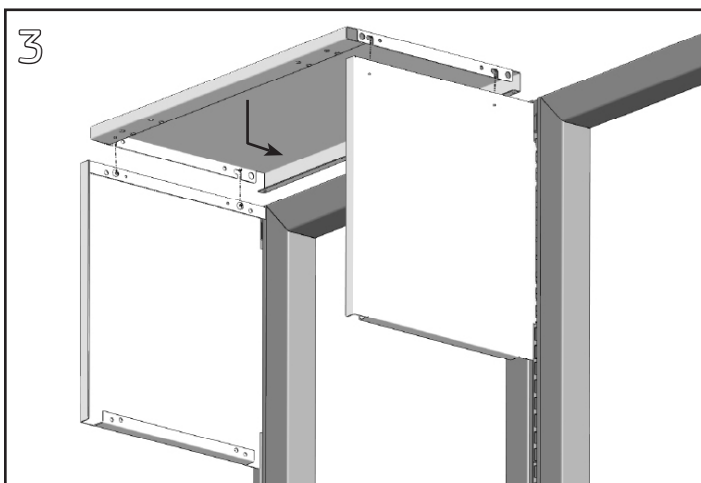

Align the slots in the side flanges of the top panel with the screws installed at the top of the end panels. Slide the top panel down and back towards the frame/panel.

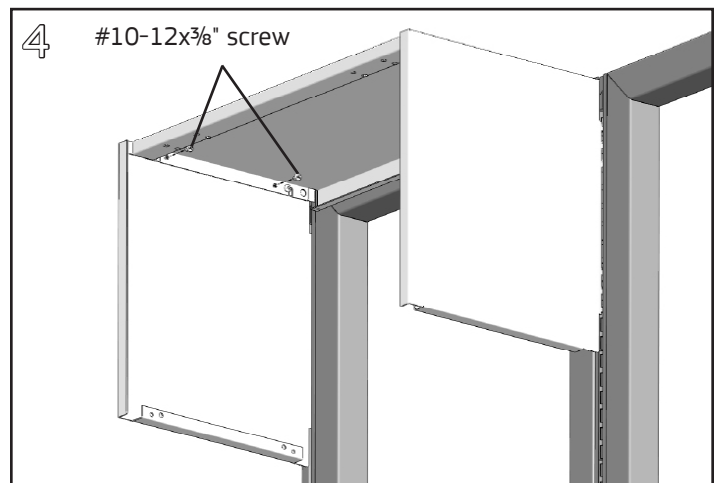

Install two more #10-12x $\frac{3}{8}$ " Phillips pan head screws in the top of each end panel to lock the top panel into position and fully tighten all screws with a #2 Phillips screwdriver/bit with driver.

Storage Cabinet Assemblies

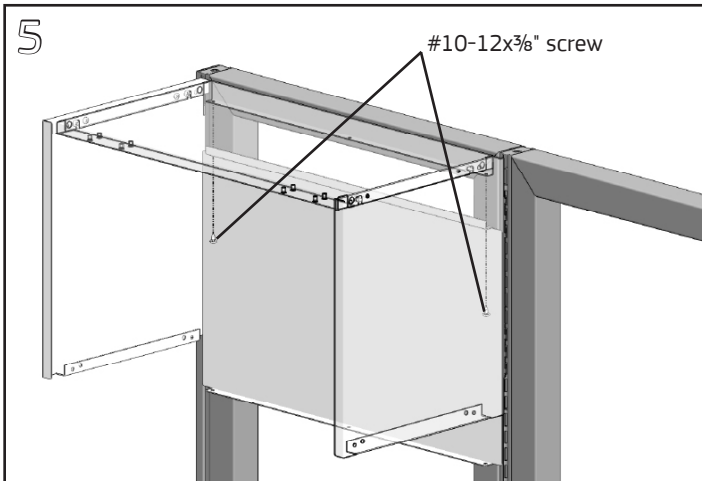

Slide the back panel up between the end panels and fasten with two #10-12x $\frac{3}{8}$ " Phillips pan head screws to the top panel.

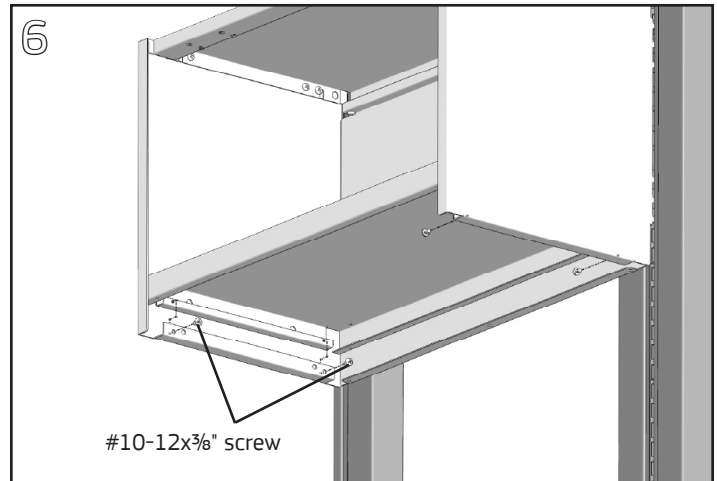

Place the shelf inside the cabinet with the rectangular lock cut-outs at the front. Install two #10-12x $\frac{3}{8}$ " Phillips pan head screws through the flange at the bottom of each end panel to secure the shelf.

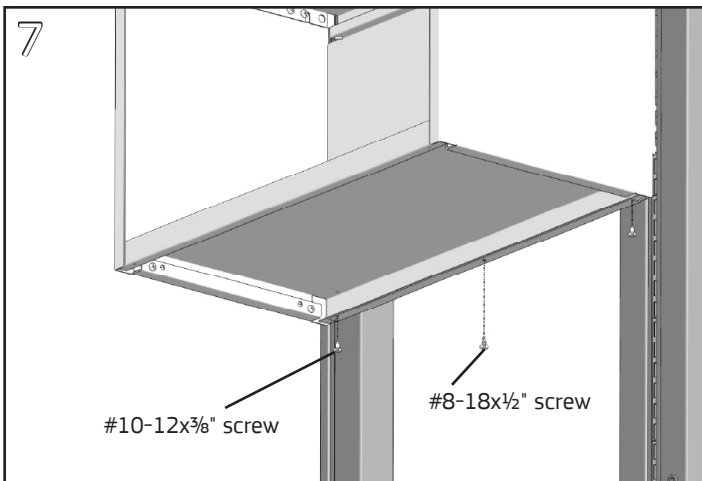

Fasten the back panel to the shelf by installing a #10-12x $\frac{3}{8}$ " Phillips pan head screw on the bottom in each corner, and a #8-18x $\frac{1}{2}$ " Phillips pan head self-drilling screw in the center back panel hole.

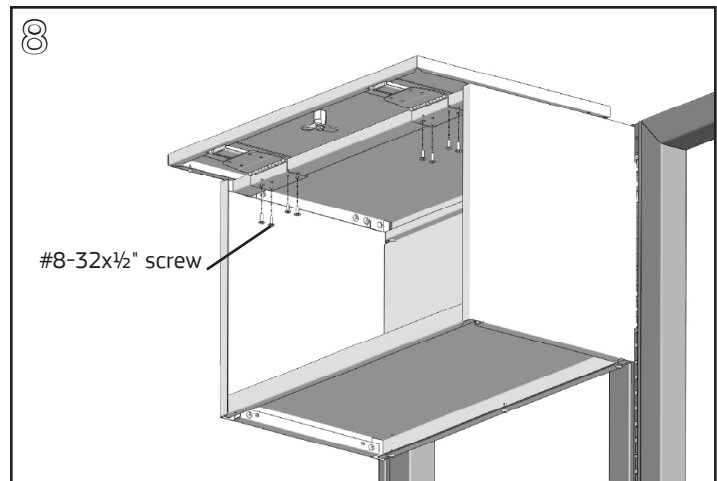

Pull the sliding hinge brackets toward the lock on the door assembly. Place door on top of cabinet and align hinge bracket slots/holes with the threaded inserts in the bottom flange of the top panel. Fasten door to top with eight #8-32x $\frac{1}{2}$ " Phillips truss head screws using a #2 Phillips screwdriver/bit with driver.