

## PATCH PANEL ASSEMBLY AND BACK COVER

*Note: Patch Panel Assemblies (PPA2USB) each include a 2 unit 24 port Patch Panel with 24 mounting collars, a pair of 2 unit Flush Rack Mount Brackets, a 2 unit clear acrylic Back Cover and all mounting hardware.*

*Patch Panel Back Covers (PPC2U) each include a 2 unit clear acrylic Back Cover and the hardware for mounting it to field-installed Patch Panels.*

### Patch Panel Assembly

1. Install the necessary data ports in the Avaya M1000PMC-B mounting collars that are assembled in the 2 unit high Patch Panel.

2. Install the left and right brackets per **RACK MOUNT BRACKETS, 19" EIA** installation instructions.

3. Install the Patch Panel using the #10-32 x 5/8" Phillips truss head screws provided (Figure 1).

4. Fasten each of the four hexagonal stand off rods to the ends of the #10-32 x 5/8" Phillips screws used to secure the patch panel. Tighten rods completely (Figure 2).

5. Place the back cover over the stand off rods and align the four holes in the back of the cover with the four stand off rods. The cover can be installed with the cord clearance notch directed up or down (Figure 2).

6. Install a #10-32 x 1/2" thumb screw through each hole in the back cover and into the tapped end of the stand off rod. Tighten the thumb screws completely (Figure 2).

### Patch Panel Back Cover

1. At desired location in a Rack Module or on Rack Mount Brackets, install a 2 unit Patch Panel using #10-32 x 5/8" Phillips truss head screws. (Figure 1)

2. Finish installation of Back Cover beginning with Point #4 above.

*Patch Panel Back Cover Hardware Pack – PPCHP (#01091102-01)*

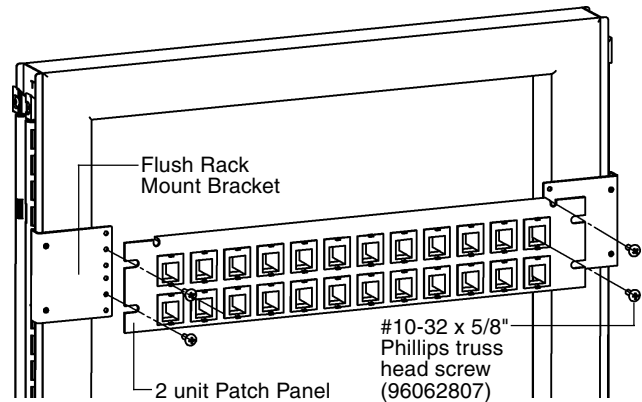

Figure 1

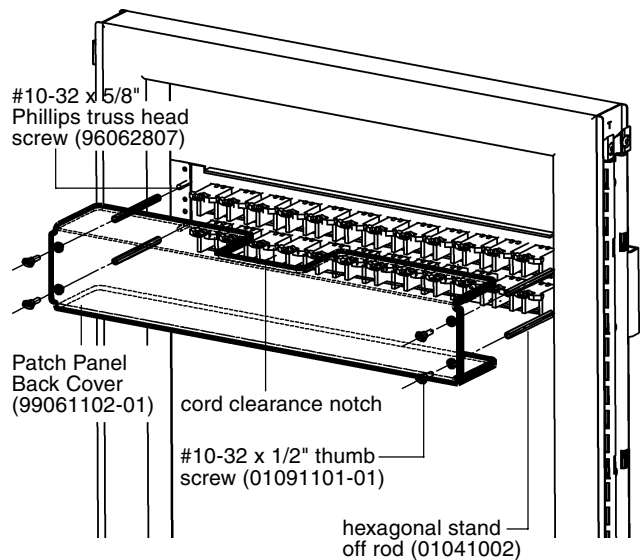

Figure 2